



Standard Specifications

CITY OF KITCHENER

Development Services Department  
Engineering Services  
Revised November 2022

## City of Kitchener Standard Specifications (CKSS)

The Corporation of The City of Kitchener Standard Specifications are supplemental specifications and amend and take precedence over the Ontario Provincial Standard Specifications, the Ministry of Transportation of Ontario, the Regional Municipality of Waterloo Standard Specifications (RWSS) and Special Provisions (RWSSP), the Region of Waterloo and area municipalities Design Guidelines and Supplemental Specifications for Municipal Services (DGSSMS), and the City of Kitchener Development Manual (CKDM).

Where these specifications are used for work done by a utility proponent or other Contractors not working on a City of Kitchener contract, clauses in these specifications related to “Measurement of Payment” and “Basis for Payment” do not apply.

### Definitions

#### **Section 100**      **General**

CKSS 150	Allowance for Water Treatment
CKSS 151	Construction near Trees
CKSS 152	Provide Performance, Labour, and Material Payment Bonds
CKSS 153	Site Specific Health and Safety Plan
CKSS 154	Lines and Grades
CKSS 180	Management of Excess Materials

#### **Section 200**      **General Grading**

CKSS 201	Clearing, Close Cut Clearing, Grubbing
CKSS 206	Grading
CKSS 209	Embankments

#### **Section 300**      **Pavement**

CKSS 310	Hot Mix Asphalt
CKSS 311	Asphalt Driveway, Boulevard and Multi-Use Trail
CKSS 314	Untreated Granular Sub Base, Base, Surface, Shoulder, and Stockpiling
CKSS 351	Concrete Sidewalks, Driveway Ramps and Driveways
CKSS 352	Concrete Steps
CKSS 353	Concrete Curb and Gutter
CKSS 355	Interlocking Concrete Pavers
CKSS 356	Pervious Concrete Pavement

**Section 400**      **Drainage, Watermains, and Utility**

CKSS 401	Trenching, Backfilling, and Compacting
CKSS 405	Pipe Subdrains
CKSS 407	Maintenance Hole, Catchbasin, Ditch Inlet and Valve Chamber Installation
CKSS 408	Adjust Frames and Covers
CKSS 409	CCTV Survey and Mandrel Testing of Sewers
CKSS 410	Pipe Sewer Installation
CKSS 416	Pipeline Installation by Jack and Bore
CKSS 441	Watermain Installation
CKSS 442	Corrosion Protection of Watermains
CKSS 480	Exfiltration Trench Systems
CKSS 481	Observation Ports for Infiltration Systems
CKSS 482	Riser Pipe Outlet Structure
CKSS 483	Headwall Structures
CKSS 491	Preservation, Protection, and Reconstruction of Existing Facilities
CKSS 493	Temporary Potable Water Supply System

**Section 500**      **Miscellaneous**

CKSS 510	Removal
CKSS 517	Dewatering of Excavation
CKSS 518	Groundwater Treatment
CKSS 560	Precondition Survey of Structures
CKSS 561	Test Pits for Soil Characterization
CKSS 562	Provide Garbage, Recycle, Green Bin and Yard Waste Pick Up and Transportation
CKSS 563	Railway Flagman and Inspection
CKSS 564	Unshrinkable Backfill
CKSS 565	Site Office

**Section 600**      **Electrical**

CKSS 603	Installation of Ducts
CKSS 609	Grounding

**Section 700**      **Traffic Safety**

CKSS 706	Traffic Control, Vehicular and Pedestrian Signage
CKSS 710	Pavement Markings
CKSS 760	Traffic Sign Installation

**Section 800**      **Environmental and Landscape**

CKSS 801	Provide Tree Protection
CKSS 802	Topsoil
CKSS 803	Sodding
CKSS 804	Seed and Cover
CKSS 805	Temporary Sediment and Erosion Control Measures
CKSS 850	Terraseeding
CKSS 851	Landscaping
CKSS 860	Bioretention Facilities

**Section 900**      **Structural**

CKSS 914	Waterproofing Bridge Decks with Hot Applied Asphalt Membrane
CKSS 960	Retaining Wall

**Section 1000**      **Aggregates**

CKSS 1010	Material Specifications – Base, Subbase, Select Subgrade, and Backfill Material
-----------	---

**Section 1300**      **Cement and Concrete**

CKSS 1303	Material Specification – Admixtures for Concrete
CKSS 1350	Material Specification – Concrete

**Section 1800**      **Pipes and Associated Drainage Items**

CKSS 1851	Material Specification – Catchbasin Quality Control Devices
CKSS 1860	Material Specification – Geotextile
CKSS 1861	Material Specification – Geogrid
CKSS 1870	Material Specification – Bioretention Filter Media



## Definitions

**Boulevard** means that part of the road from the edge of the roadway to the nearest property line.

**Driveway** means that part of the City or Regional Road that provides vehicular access to and from the roadway and an adjacent property.

**kg** means kilograms

**m** means metres

**mm** means millimetres

**PGAC** means Performance Graded Asphalt Cement.

**Proponent** means a person who undertakes Work on a City or Regional road, not including any person working under contract with the City or Region.

**Provide** means supply labour, materials and equipment required for complete installation of the work.

**Region** means The Regional Municipality of Waterloo.

**Regional Road** means a road under the jurisdiction of the Region.

**road** includes, but is not limited to, a common and public highway, street, avenue, un-assumed public right-of-way, parkway, driveway, square, place, bridge, viaduct or trestle, any part or which is intended for or used by the general public for the passage of vehicles and includes the area between the property lines thereof.

**roadway** means that part of a City or Regional road either that is improved, designed or ordinarily used for vehicular traffic including cycling lanes, shoulders and curb and gutter.

**sidewalk** means that part of a City road with a surface improved with asphalt, concrete or gravel for the use of pedestrians.

**vehicle** includes, but is not limited to, a motor vehicle, trailer, traction engine, farm tractor, road-building machine, bicycle and any vehicle drawn, propelled or driven by any kind of power including muscular power.

## **CKSS 150**

### **ALLOWANCE FOR WATER TREATMENT**

#### **150.01 General**

The allowance for water treatment is intended to cover the cost of contaminated groundwater treatment and disposal as outlined in the Schedule of Unit Prices should they be required over the course of this project.

#### **150.02 Basis for Payment**

The allowance for water treatment is intended to cover the cost of contaminated groundwater treatment and disposal as per the items in the Schedule of Unit Prices.

All payments under this item shall be approved in advance, and in writing, by the Contract Administrator and the Owner. Under no circumstances shall the Contractor proceed with expenditure of this item without prior knowledge of the Owner and approval from same. In the event that all or a portion of the allowance is not expended on this project, the Contractor shall not be entitled to payment of this lump sum Contract item.

## CKSS 151 CONSTRUCTION NEAR TREES

### REFERENCES

City of Kitchener Municipal Tree By-Law

#### 151.01 Definitions

**Border Trees** means trees that have only part of their trunk, at ground level, growing on municipal lands. These trees have joint ownership.

**City Tree** means trees that are owned fully by the municipality and are those trees where the full trunk, at ground level, is located on municipal lands.

**Critical Root Zone (CRZ)** means the area that extends from the trunk of the tree to at least the outer limits of the crown of the tree. Unless specifically stated the TPZ does not extend into the roadway, but does extend into the front lawn where trees are located in the boulevard.

**DBH** means the Diameter at Breast Height, taken 1.4 metres above ground level.

**Guide for Plant Appraisal** means the Council of Tree & Landscape Appraisers, most recent edition.

**Root Habitat Conservation Zone (RHCZ)** means the area that extends 1 to 2 times beyond the tree's dripline, and reflects the root habitat required for healthy, mature trees. In residential areas this zone includes the boulevard, front lawns, driveways and side lawn. Tree root growth is highly variable.

**Root Plate** means the area at the base of a tree where the roots and stem merge, see the Tree Management Plan Detail for more information.

**Scaffolds** means the primary structural branches of the crown

**Tree Protection Zone (TPZ)** means the area of ground surface being protected from damage by mechanical excavation, including sidewalk.

**Urban Forestry** means a representative from Operations Division, Design and Development or its designate.

#### 151.02 General

Where it has been determined that the Contractor has 1) failed to comply with the required tree protection measures and / or 2) causes unauthorized damage to a City or Border tree the Contractor will be responsible for the following as determined by Urban Forestry and Contract Administration Services.

1. For each incident for which the Contractor is responsible, the Contractor will:
  - 1.1. Be charged an assessment fee of \$1,500 for each tree not identified as being a Significant Tree.
  - 1.2. Be charged an assessment fee of \$2,500 for each tree identified as being a Significant Tree.
  - 1.3. On projects of high value, Urban Forestry in consultation with the Contract Administrator may decide to set higher values for specific projects. Higher values will be identified in the tender documents.

- 1.4. Be responsible for any additional costs borne by Urban Forestry in excess of those stated in Part 1.1 and 1.2. This may include, but not be limited to: tree inspection / consulting / assessment costs and any required remedial arboricultural treatments (e.g. tree pruning, wound treatment, watering).
  - 1.5. Provide any assistance in terms of on-site equipment, labour requested by Operations at no cost to the Owner.
  - 1.6. Adhere to any written direction by Urban Forestry and the Contract Administrator to prevent additional damage.
2. Where Urban Forestry identifies a long-term concern regarding the trees' structural integrity and health because of unauthorized construction damage the Contractor will also be responsible for the following:
    - 2.1. For a period of two years, the Contractor will be responsible for any additional costs borne by Urban Forestry in excess of those stated in all of Part 1. This includes, but is not limited to; tree inspection / consulting / assessment costs and any required remedial arboricultural treatments (e.g. tree pruning, fertilization, watering).
    - 2.2. Where the tree has been damaged to the degree that it is unsafe or deemed unworthy of preservation, either; 1) at the time of the incident or 2) during the two year period after the contract, the Contractor will be responsible for the value of the tree as determined by the Guide for Plant Appraisal, along with the removal and replacement costs of the tree as determined by Urban Forestry and the Contract Administrator.
3. When a Subcontractor is working on the site all costs all fees associated with damage will be assigned to the General Contractor.
  4. All assessed and associated costs identified in the foregoing sections will be deducted from the total amount payable to the General Contractor through the contract between the Owner and the General Contractor.
  5. All tree issues on public lands, unless otherwise noted, are the responsibility of Urban Forestry. Urban Forestry is solely responsible for the assessment of all damage to trees, tree appraisal, and decisions regarding remedial arboricultural treatments, decisions regarding any tree removals and all recommendations regarding new tree plantings.

### **151.03 Kitchener's Municipal Tree Bylaw**

Section 690.4.1 states that; "Any Contractor, commission or corporation or any other organization, person or individual, having a contract for paving streets, constructing sidewalks or excavating or doing any work on City property, shall when executing such work or contract take all necessary steps to avoid injuring any tree and in this connection, shall obey any lawful direction given by a responsible officer of the Department."

### **151.04 Tree Protection During Construction**

Where protective measures are not taken around trees, construction activities can have a significant and long-term effect on trees resulting in their decline and death.

- Under Chapter 690.4.1 these specifications state the standard practices that will be carried out while working around City / Border Trees.

- In reading this document the Contractor shall also refer to the tender documents, the tree management and planting plan, and details in the drawing set. Additional tree protective measures for specific projects are stated in the Tree Management Plan. Where a difference in the level of protection exists between this Specification and the Tree Management Plan, the level of protection stated in the Tree Management Plan will be followed.
- During the length of this contract the Urban Forestry Representative may request additional tree protective measures.
- Where the Contractor fails to carry out the required tree protective measures and / or cause unauthorized damage, the Contractor will be responsible for any costs and associated responsibilities assigned to the Contractor.
- With respect to this contract, Urban Forestry is solely responsible for the assessment of all damage to trees, tree appraisals, and decisions regarding remedial arboricultural treatments, tree removals and recommendations regarding new tree plantings.

## **151.05 Tree Management Plan**

### **151.05.01 Critical Root Zone (CRZ)**

Critical Root Zones extend from the trunk of the tree to at least the outer limits of the trees crown. Urban Forestry may identify larger protection zones for Significant Trees. Unless stated in the Tree Management Plan, the Critical Root Zones does not extend into the roadway.

### **151.05.02 Significant Trees**

Significant Trees are high value old growth trees that have special tree maintenance and protection measures applied. Urban Forestry may also identify other trees as being significant due to their social, heritage or environmental values. Significant Trees are identified with an “S” on the drawings. All standard protective measures and any additional measures stated in the Tree Management Plan apply. Significant trees have larger CRZ, and higher damage assessments.

### **151.05.03 Protective Fencing**

Prior to the commencement of any construction activity that may injure a tree on the site; the Contractor shall install all tree protective fencing identified on the Tree Management Plan. The Contractor will notify the Urban Forestry representative prior to starting construction to confirm that the tree protection is in place.

No work can occur within the TPZ unless authorized by the Urban Forestry Representative.

Protective fencing will remain in place until the site is ready for sod and tree planting.

If some fill or excavated material shall be temporarily located near the tree protection barrier, a wooden barrier shall be used to ensure no material enters the TPZ.

The Urban Forestry representative may request that fencing be installed closer to the back of curb or edge of paved surface.

### **151.05.03.01 Trees located within boulevard**

Fencing will fully enclose the TPZ (except where limited by an existing paved surface). It is to be installed 300 mm behind the curb, and 200 mm from the edge of all other paved surfaces (sidewalk, driveway ramps etc.)

### **151.05.03.02 Trees located within the front lawn**

Fencing will be placed along the full length of the TPZ (except where limited by an existing paved surface) and be installed 300 mm in from the back of sidewalk.

### **151.05.04 Tree Signage**

Urban Forestry will install Tree Protection Signs along the protective fencing. Signs will not be removed without the approval of Urban Forestry and will be returned to the Kitchener Operations Facility at 131 Goodrich Drive at the end of the contract.

## **151.06 Restrictions within Tree Protection Zones**

Except where stated in this specification and approved within the Tree Management Plan the following activities and practices are prohibited within the Critical Root Zone;

- 1.1. No mechanical damage to the trees root plate, tree trunk or scaffolds will occur at any time. Excessive and careless damage to tree branches is also prohibited.
- 1.2. No open excavation will occur within the Critical Root Zone.

**Exception:** Where approved in the Tree Management Plan the Contractor will carry out Boring \ Hydrovacating \ Excavating as directed within the Critical Root Zone to establish services to the property line. For all lateral sanitary sewers the Contractor will identify and mark the location of the lateral sewer using an electronic pipe and cable locator. The location of the pipe will be marked on the surface from the edge of the road to one (1) metre beyond property line. The Contractor, Urban Forestry Representative and Contract Administrator will review all works within the Critical Root Zone prior to any work starting. Urban Forestry will determine the appropriate work method including open excavation, hydrovacating, or the use of a small excavator. Urban Forestry may request that exploratory root work with the use of a hydrovac is carried out first. Once the work method is approved all roots greater than 2.5cm will be cut cleanly with a pruning saw, no roots larger than 10cm will be cut without the approval of Urban Forestry. Backfilling will occur as soon as possible and soil will be placed along the edge of the root cut zone to minimize root desiccation. Where backfilling cannot occur immediately after the work, the Contractor will cover the hole with plywood to protect the roots of all Significant Trees.

- 1.3. No construction materials, excavated soil, waste material, construction trailers, storage areas, chemical or washout water will be deposited or stored within the critical root zone habitat or root habitat conservation zone.

**Exception:** Where approved by Urban Forestry the Contractor may temporarily store excavated soils within the Critical Root Zone or RHCZ. All excavated material will be placed on plywood sheets so that all excavated material is confined to the plywood area. Excavated material will not be stored in the Critical Root Zone for more than 24 hours.

- 1.4. No equipment will be parked or move through the tree protection zone.

**Exception:** Where approved the Contractor may operate equipment within the Critical Root Zone. Wherever possible hydraulic shovels will operate from the roadway. If equipment must be physically located within the Critical Root Zone the Contractor will follow all directions specified by Urban Forestry and the Contract Administrator.

1.5. No construction vehicle within the roadway will be left idling under a tree unless it is being used.

### **151.07 Tree Roots within the Roadway**

Critical Root Zones do not extend into the existing roadway unless stated in the Tree Management Plan. Where roots are encountered within the roadway the following procedures will be carried out.

- 1.1. Where a Significant Tree has been identified in the Tree Management Plan as requiring a root inspection no road excavation will occur until the root inspection has been completed. A root inspection by the Urban Forestry Representative will be carried out after the asphalt and curbs have been removed. The Contractor will provide any assistance requested by Urban Forestry. Additional protective measures may be applied to these trees after the inspection.
- 1.2. Where excavation within the roadway occurs within 2m of a tree not identified as Significant the Contractor will cut cleanly all roots greater than 2.5cm at the limits of excavation.

### **151.08 Tree Roots and Curb Removal / Installation**

Curb removal will be done with care, if necessary curb removal will be done by hand to minimize damage. Within the Critical Root Zone no excavation beyond the original curb will occur until reviewed by the Community Services Representative and Project Contract Administrator. To minimize root damage the Contractor may be required to hand form, limit excavation from back of curb or carry out other steps.

### **151.09 Sidewalk Reconstruction**

Where identified in the Tree Management Plan existing sidewalks will be left intact within the Critical Root Zone.

Sidewalk removal within the Critical Root Zone will be done with care. If required the Contractor will manually remove the sidewalk to minimize tree damage. Equipment used to remove sidewalks will work as much as possible outside of the Critical Root Zones. Equipment working within the Critical Root Zone and travel through the zone will be limited and done with care.

The Project Contract Administrator and the Urban Forestry Representative will review all sidewalk construction within Critical Root Zones, prior to sidewalk reconstruction, to identify any conflicts with existing roots and the new sidewalk. Where necessary changes in the sidewalk grade, design or construction may be required.

The Contractor will use appropriate work practices so as not to tear, or damage any roots under or adjacent to a sidewalk, unless approved for removal. All roots approved for removal that are larger than 5cm will be cut cleanly with a pruning saw. No root will be left exposed and all roots to be protected will be covered immediately to minimize desiccation.

### **151.10 Landscape Restoration**

No re-grading or restoration will occur within the limits of the Critical Root Zone, unless approved by Urban Forestry. Only disturbed areas previously approved will be restored. Where required restoration will be limited to top dressing and seeding, work within this area may require hand work.

### **151.11 Tree Removals, Pruning, Stumping**

Unless identified on the Tree Management Plan the Contractor will not remove any City or Border Tree, or carry out any arboricultural treatments unless approved by Urban Forestry.

Where the Contractor is permitted to remove trees and grind stumps all work will be carried out by qualified and competent tree workers with demonstrated work experience within urban residential areas. The work will be done using approved arboricultural practices (e.g. tree removals, rigging, aerial lifts, etc.) and will be consistent with all provincial regulations and industry standards.

The Contractor shall not remove any trees on the site, regardless of their designation on the Tree Management Plan prior to seeking approval from Urban Forestry.

### **151.12 Private Trees**

Urban Forestry has no jurisdiction over trees growing on private property, however the City has the same level of interest in protecting private trees as it does City trees. The Contractor will follow all direction by the Contract Administrator and Urban Forestry to work around and protect private trees.

## **CKSS 152 PERFORMANCE, LABOUR, AND MATERIAL PAYMENT BONDS**

### **152.01 General**

The value of the performance bond shall be equal to one hundred percent (100%) of the contract price.

The value of the labour and materials payment bond shall be equal to fifty percent (50%) of the contract price.

### **152.02 Measurement for Payment**

Payment of this item shall be fifty (50) percent of the lump sum unit price upon mobilization by the Contractor to the site. The remaining amount shall be pro-rated to match the percentage of the work completed at the time of each progress payment certificate.

### **152.03 Basis for Payment**

The work of this item shall include all costs associated with providing these bonds.

## **CKSS 153 SITE SPECIFIC HEALTH AND SAFETY PLAN**

### **153.01 General**

To ensure such that workers and public are protected from any adverse effects due to excavation and/or handling of impacted materials. A Site Specific Health and Safety Plan (HASP) relating to construction activities shall be prepared by the Contractor prior to commencing field work. The HASP should be designed to identify potential hazards, which will likely be encountered by personnel at the Site during assessment or construction activities. All activities at the site shall be conducted in compliance with applicable federal, provincial, and municipal regulations.

Regular Health and Safety meetings will be held by the Contractor to review compliance.

As a minimum, the Contractor shall consider in its Health & Safety Plan:

### **153.02 Spill Procedures**

The following are spill procedures which are to be posted at the site trailer:

- Determine nature of spill and method of safe response;
- Terminate the spill and contain spilled material;
- Contact the MECP Spill Action Centre at 1-800-268-6060;
- Undertake clean-up and appropriate verification sampling; and,
- Provide proper waste manifesting and disposal to a facility licensed to accept the material.

### **153.03 Fire**

Any fire would be reported to the local fire department and MECP Spills Action Centre for appropriate response.

### **153.04 Workplace Accident**

Respond with first aid, and then notify the local Hospital of situation and transport injured person or call 911 Emergency as the severity of the case requires; and, Contractor to advise the Ministry of Labour as per the requirements of the Occupational Health and Safety Act.

### **153.05 Levels of Protection**

Required personal protective equipment; chemical-resistant or leather boots, with CSA approved safety toe and steel shank; shirt and pants under disposable or site dedicated coveralls; hard hat; optional personal protective equipment; chemical resistant outer gloves; safety glasses with side shields, or splash goggles, or face shield; and, hearing protection.

Contractors Site Safety Officer shall:

- Choose protective clothing and equipment (PPE);
- Conduct regular safety meetings with workers;
- Provide appropriate disciplinary action when unsafe acts or practices occur;
- Provide emergency treatment and decontamination procedures for the specific type of exposure that may occur at the site;
- Periodically inspect protective equipment;
- Ensure that protective clothing and equipment are properly stored and maintained;

- Ensure entry and exit at the Access Control Points;
- Confirm each team member's ability to perform;
- Monitor the works parties for signs of stress;
- Monitor on-site hazards and conditions;
- Know emergency procedures, evacuation routes, and the telephone numbers of the ambulance, local hospital, poison control centre, fire department, and police department;
- Coordinate emergency medical care;
- Set-up decontamination lines and decontamination solutions appropriate for the type of chemical contamination on site;
- Control the decontamination of all equipment and personnel; and,
- Ensure that all required safety equipment is available and in proper working order.

### **153.06 Air Monitoring Program**

When contaminated fill is encountered during on-site excavation and construction activities, monitoring of air quality will be completed by the Contractor's Site Safety Officer for worker protection and adherence to the Contract, and in order to ensure the protection of human health and the environment.

The lab results of the air quality will be reported to the Owner on a daily basis, and will be used by the Owner for evaluating the effectiveness of the control measures employed by the Contractor, during the work.

Hand-held, real time measurement devices can be used to collect on-going information related to the presence of air borne dust and contaminants during soil excavation. A meteorological station can be set up in order to evaluate wind direction, speed and ambient temperatures.

Ambient air quality shall be monitored in order to confirm that dust and airborne contaminant control measures are effective, and to ensure that any potential off-site air quality impacts caused by the operations are minimized. Air quality monitoring shall be conducted during excavation at upwind/downwind locations as per O. Reg. 419/05. These measures will be used to verify that fence line concentrations of relevant parameters are within acceptable limits, as defined by MECP and/or assist in identifying the need for specific control measures.

Portable testing equipment includes but may not be limited to:

- Photo-Ionization Equipment – monitor for the presence of VOCs; and
- Multi-Gas Meter(s) – monitor the excavation and breathing zone for levels of oxygen, methane, carbon monoxide, hydrogen sulphide, and combustible vapours.

### **153.07 Basis for Payment**

Payment for this item shall include time required to make any revisions based on comments by the Owner, Ministry of Labour, or other stakeholders, as well as a training seminar conducted by the Site Safety Officer to present the HASP to all project personnel. This item also includes payment for the Site Safety Officer along with necessary monitoring and reporting, equipment / supplies, to carry out their duties throughout the project. Reporting to consist of weekly summaries in a format suitable to the Owner, and to include at a minimum a summary of air quality data collected, odour complaints received, visitation by regulatory authorities, incidents, direction to the Contractor (if any).

Payment will be made on a pro-rated basis determined on each payment certificate based on the percentage of project completed.

## **CKSS 154 LINES AND GRADES**

### **154.01 General**

Any work done without lines and levels, or to improperly set grade stakes or without the supervision of an inspector when an inspector is required to be in attendance by the provisions of the contract or by the order of the Contract Administrator, shall not be paid for. Such work may, at the discretion of the Contract Administrator, be ordered removed and replaced by correctly aligned and inspected work at no cost to the Owner.

If requested by the Contractor in writing, the Contract Administrator will provide, if available, electronic data to assist the Contractor in laying out the works. The software format and version supplied to the Contractor will be the same version as that used to create the files. The Contractor Administrator will not convert the electronic data between software platforms or versions of the same software platform. It is the Contractor's responsibility to ensure that the electronic data is the same as the Contract Drawings. In the event of any discrepancy between the Contract Drawings and the electronic data, the Contract Drawings shall take precedence and govern. Any discrepancies shall be reported immediately to the Contract Administrator.

Any manipulation of any part or parts of the electronic data by any party, including a Contractor, proponent, or any party or parties carrying on any work associated with the project, is at the sole risk and responsibility of such party or parties.

The electronic data provided will normally include but may not be limited to:

- Existing topographic survey
- Survey control points and benchmarks
- Original ground triangulated irregular network (TIN) surface
- Road alignments
- Location of the proposed works
- Road profiles
- Watermain alignment and profile
- Sanitary and storm sewer layout and profiles
- Proposed TIN surface

### **154.02 Measurement for Payment**

Payment for this item will be pro-rated to match the percentage of the work completed at the time of each progress payment certificate.

### **154.03 Basis for Payment**

Payment for all labour, materials and equipment for the Contractor to provide construction layout shall be paid under the lump sum bid price for the item provided in the Schedule of Unit Prices.

## **CKSS 180 MANAGEMENT OF EXCESS MATERIALS**

### **REFERENCES**

OPSS.MUNI 180 – Management of Excess Materials  
OPSS.MUNI 206 – Grading  
O.Reg 406/19 – On-Site and Excess Soil Management

#### **180.01 General**

Excess materials shall be managed in accordance with O.Reg 406/19 On-Site and Excess Soil Management, OPSS.MUNI 180, as supplemented and amended by the following additional requirements. The Contractor shall make every effort to reuse excess material as suitable backfill.

All excavations shall be done in accordance with the latest edition of the Occupational Health and Safety Act, and provincial regulations. The Contractor shall be responsible for the condition of all excavations. All slides and cave-ins shall be removed without extra compensation, at whatever time and under whatever circumstances they may occur.

Excess material that includes asbestos waste shall be managed in accordance with all applicable legislation, including but not limited to, Ontario Regulation 278/05 (as amended).

For all excess materials the Owner has not designated or identified specific haulers, receivers, and/or disposal sites for excess materials generated under this Contract. The Contractor shall be solely responsible for identifying and selecting appropriate haulers, receivers, and/or disposal sites required to complete the work of this Contract, subject to acceptance of the Owner where specified.

The Contractor shall name all haulers, receivers, and/or disposal sites for all excess materials in the spaces provided in the Tender Submission and shall attach additional sheets as necessary.

If applicable, re-use and disposal sites of Excess Soil may be stipulated in the Excess Soil Destination Report or equivalent, included with these Contract Documents. For all Excess Soil where no re-use or disposal site has been stipulated in the Contract Documents, the Contractor shall indicate intended re-use and/or disposal sites in the spaces provided in the Tender Submission. Use of the bidder's indicated re-use and/or disposal sites is at the discretion of the Contract Administrator.

The Contractor shall be responsible for all arrangements with the waste hauler, and site facility, including any analytical data required by the disposal or reuse site. The Contract Administrator will provide the Contractor with all available characterization data.

#### **180.02 Submittals**

The Contractor shall submit a plan of any temporary on-site storage areas for the duration of the project. The plan shall include the erosion and sediment controls.

The Contractor shall provide a written description of their approach to Excess Soil management as defined in O.Reg 406/19 for this contract illustrating their understanding of the requirements and how they will be addressed (Excess Soil Reuse Plan).

The Contractor shall develop and submit a plan for the transportation, disposal and tracking of Excess Soils to meet the requirements identified under O.Reg 406/19. The plan shall list all carriers who will haul the soil to the Reuse Site(s). The Contract Administrator shall approve listed haulers in advance of any excavation work. The plan shall also include details of the tracking system to be used.

Contractor shall provide a detailed report of excess soil movement from the site in accordance with the details of the tracking requirements outlined in this specification.

The Contractor shall submit all relevant documentation as described herein. All required submissions shall be provided by the Contractor to the Contract Administrator prior to Certification of Substantial Performance.

Additionally, the Contractor shall provide the following to the Contract Administrator for review and approval prior to, and as a prerequisite, to mobilization. Any delays resulting from late, incomplete, or inaccurate submittals shall be the sole responsibility of the Contractor and the Owner will not be responsible for any claims for compensation for delays associated with incomplete or incorrect submittals.

A minimum of ten (10) working days prior to commencing the removal of excess earth from the Working Area, an Excess Soil Reuse Plan shall be submitted to the Contract Administrator for excess earth subject to the requirements of O. Reg. 406/19 and Rules for Soil Management and Excess Soil Quality Standards, for information purposes only.

The plan shall include the following information for each reuse site proposed in the bid submission:

- a) The municipal address (if applicable), latitude and longitude, in NAD83 or WGS84 coordinate system, and description of the reuse site, and contact information of personnel representing the Reuse Sites;
- b) The property use of the reuse site and any characteristics associated with the reuse site or nearby properties that may affect the excess soil quality standards applicable to the reuse site;
- c) A description of the undertaking or the identified beneficial purpose for which the excess soil is to be reused;
- d) The estimated quantity of excess soil, including any salt impacted quantities, to be managed at the reuse site and that are necessary for the identified beneficial purpose;
- e) The applicable excess soil quality standards for the reuse site, as determined according to:
  - i. the excess soil standards, and/or;
  - ii. the site-specific excess soil quality standards developed, in accordance with the Rules for Soil Management and Excess Soil Quality Standards, for the reuse site according to the Beneficial Reuse Assessment Tool (BRAT) available on the Government of Ontario website;
- f) Documentation showing that appropriate landowner consultation and disclosure has taken place and confirmation of the site owner's / operator's written consent to accept the excess soil;
- g) Completed copies of OPSF 180-1 and/or OPSF 180-2;
- h) If the reuse site is or will be governed by a site-specific instrument, identify the instrument, the public body responsible for issuing the instrument and any other information relevant to the reuse of excess soil at that site; and
- i) The record keeping/tracking system to be employed, according to the Rules for Soil Management and Excess Soil Quality Standards as applicable, to track excess earth movements during its transportation and placement at the reuse site. Tracking system shall be digital and provide:

- The location at which the Excess Soils, were loaded for transportation.
- The date and time the Excess Soils, were loaded for transportation.
- The quantity of Excess Soils, in the load.
- The name of an individual who may be contacted to respond to inquiries regarding the load, including inquiries regarding the soil quality.
- The name of the corporation, partnership or firm transporting the Excess Soils, the name of the driver of the vehicle and the number plates issued for the vehicle under the Highway Traffic Act.
- The name and location of the Reuse Site.
- The date and time of arrival of the load to the Reuse Site.
- The volume of Excess Soils, received.
- Documentation from the Project Area signed by a QP, including soil analytical results.
- Written consent from the Reuse Site accepting and acknowledging that the incoming Excess Soils, are acceptable for receipt at the site, including the contact information of the person who acknowledged receipt of the load(s).
- Rejections of any loads of Excess Soils, due to visual inspection or review of analytical results.
- Documentation to the Contract Administrator, once Excess Soils are received, confirming the materials were received and the type, quality and quantity were appropriate.

### **180.03 Characterization of Excess Material**

Where noted in the contract documents, the Owner has completed geotechnical investigations in accordance with O.Reg 406/19 and includes the *Assessment of Past Uses, Sampling and Analysis Plan*, and a *Soil Characterization Report* or equivalents.

The Contractor shall review and understand the available environmental data on Excess Soils to be generated, as provided within the *Soil Characterization Report* or equivalent.

The Contract Administrator may conduct additional analytical sampling (at Owner's expense) before, during and upon the completion of soil excavation activities to review the excess soil management and disposal alternatives and to assess the environmental quality of the soil at the final limits of the excavations (walls and floor).

Where the Contract Administrator has collected soil samples for laboratory analysis, the Contractor is advised that receipt of analytical results may take approximately 3 to 5 business days. As a result, the Contractor shall guide its operations accordingly, and without claim for project delay.

The Contractor shall provide 48 hours' notice to the Contract Administrator to arrange for suitable environmental inspection of the excavation and shall cooperate fully and coordinate forces accordingly to allow for the timely sampling of the material. No areas may be backfilled until the Contractor is directed to do so by the Contract Administrator.

At the direction of the Contract Administrator, the Contractor shall backfill the area with approved material that includes the reuse of non-impacted excavated soil and clean imported fill. No compensation will be provided to the Contractor for delays while the Owner's representative is sampling the soil from the excavation and assessing the analytical results. If the analytical results indicate that the contaminants were not fully removed to allow the work to proceed, the Contractor may be required to excavate further (vertically and laterally) only upon approval of the Owner, to remove the impacted soils. The determination to remove additional material (fill or native materials) from the work area will be made by the Contract Administrator and direction provided to the Contractor.

The Owner shall provide available information on the characterization of soils in the project area for the purposes of identifying appropriate reuse or disposal locations. The Contractor shall be responsible for any sampling and analysis that are additional requirements of the approved Reuse Site or disposal site.

#### **180.04 Soil Management**

The Contractor shall be responsible for the on-site and off-site deposit of Excess Soils from the project area and will be responsible for executing the requirements of the Reuse Site in relation to import of Excess Soils originating from another site. This shall include all necessary additional sampling, documentation and reporting to support placement of material at the Reuse Site(s) including the identified submittals.

All excess material shall be transported to the Reuse Site(s) approved by the Contract Administrator. The proposed Reuse Site(s) must be approved in advance of any excavation work. The Contractor shall obtain written consent from the operator/owner of the Off-Site Reuse Site(s) at which the Excess Soils will be deposited, prior to the initiation of construction operations.

The Contractor shall be responsible for the design, construction and maintenance of any required on-site storage areas, processing equipment, and transportation including off-site haulage and deposit of the Excess Soils.

The Contractor shall implement and maintain the approved tracking system described in the Excess Soil Reuse Plan.

The Contractor shall comply with the requirements outlined in a Fill Management Plan, should it exist for the Reuse Site, Excess Soil Destination Assessment Report and/or site-specific Instrument of the Reuse Site where Excess Soil will be placed, as applicable.

The soil hauled off-site shall be dry. Otherwise, hauling of liquid soils will be in accordance with provisions in the Soil Rules.

#### **180.05 Conditions on Management by Disposal as Non-Hazardous Waste**

All excess materials (including, but not limited to: bituminous pavement; concrete; fabricated metal and plastic; wood; masonry; pipes; surplus or unsuitable excavated earth and rock; and other wastes) that are not otherwise designated for salvage or reuse by the Owner shall be removed from the Working Area and properly transported and re-used or disposed off-site in accordance with all applicable legislation at the Contractor's sole expense. In particular, impacted soil material, exceeding the MECP Table 2 Standards, excavated from the work area shall be transported to a licensed landfill facility for final disposal.

The Contractor shall remove contaminated soils beneath the municipal road right-of-way to the limits and grades directed and approved by the Contract Administrator. Abandoned or redundant foundations or piping that is removed by the contractor shall not be mixed with contaminated materials for disposal offsite at a landfill unless specifically authorized by the Contract Administrator. During excavation activities, asbestos transite piping may be encountered. The Contractor will be required to source separate this piping and dispose of it offsite at an MECP approved landfill in accordance with all applicable regulations.

Contaminated soils that may be wet may require blending with a stabilizer for solidification before off-site disposal in order to pass slump tests. Suggested examples of stabilizers include cedar chips, sawdust, or a commercially available product.

## **180.06 Conditions on Management by Re-Use**

Following removal of the asphalt pavement, the Owner's Representative will retest the granular road base to determine whether the material is environmental and geotechnically suitable for on-site reuse as backfill (meet MECP Table 2 Standards). The Contractor shall cooperate with the Owner and construct stockpiles in locations as to not interfere with the conduct of the work. The Owner will furnish results and instructions to the Contractor regarding on-site reuse of the material within five (5) working days.

## **180.07 Hauling, Receiving, and Disposal Site**

The Contractor shall comply with the Environmental Protection Act, including Ontario Regulation 406/19, Ontario Regulation 347/90 (as amended), and shall use appropriately licensed haulers and receivers for all waste transportation and disposal, as required. A person who is operating a vehicle for the purpose of transporting the Excess Soils, shall provide the tracking information to any provincial officer, upon request.

## **180.08 Measurement for Payment**

### **180.08.01 Reuse of Soils On-site**

Where material that has been tested and determined by the Owner's Representative to be suitable for backfill onsite, the work will be paid per the cubic metre as determined through field measurements as agreed upon by the Owner and the Contractor.

Refer to CKSS 510.05.04 for predetermined quantities for soil loaded equipment.

## **180.09 Basis for Payment**

Under no circumstances shall the Contractor claim additional payment from the Owner related to the characterization of quality, designation of waste types, delineation of quality and extent of excess material, estimation of quantity, and costs (whether accurate and correct or not) associated with excavation, removal, segregation, temporary stockpiling, loading, transportation and re-use or disposal of excess materials, including excess earth and rock generated by the Contract work.

No additional payment will be made for the excavation, handling, and disposal or re-use of material excavated from the site which meets the MECP Table 1 Standards, SAR, and Electrically Conductive (EC) soil.

The work for this item shall include the supply and use of poly tarps for stockpiles as required.

### **180.09.01 Excess Soil Reuse Plan**

The work for this item shall include all labour equipment and materials required to prepare an Excess Soil Reuse Plan for management of all soils whether they are leaving the site or not.

### **180.09.02 Excess Soil Tracking**

The work for this item shall include all labour, equipment, and materials required to implement, track and report excess soil during the project.

## **CKSS 201 CLEARING, CLOSE CUT CLEARING, GRUBBING**

### **REFERENCES**

OPSS 201 – Construction Specification for Clearing, Close cut Clearing, Grubbing, and Removal of Surface and Piled Boulders

#### **201.01 Construction**

##### **201.01.01 Mechanical Stump Cutting**

The work for this item shall consist of mechanical cutting of stumps and buttress roots to a depth of 150mm below finished grade. Stump cutting will be done using an arboricultural stump grinder. All excess woody material will be removed from the site upon completion of the cutting.

#### **201.02 Measurement for Payment**

Payment will be made for each stump ground.

#### **201.03 Basis for Payment**

This work shall include all labour, equipment and materials required to grind the stump to a satisfactory depth as specified in the contract documents or as directed by the Contract Administrator.

## **CKSS 206 GRADING**

### **REFERENCES**

OPSS 206 – Construction Specification for Grading  
OPSS 501 – Construction Specification for Compacting

#### **206.01 Construction**

The Contractor shall exercise due care at all times to prevent the granular base and sub-base materials from becoming contaminated by clay or other types of deleterious materials.

The Contractor and the Contract Administrator shall jointly inspect the sub-grade prior to placement of granular materials for the road base.

#### **206.02 Measurement for Payment**

Payment will be made on a percentage completion basis to complete all work. The quantity includes roadway, driveway ramp, driveway, trails, parking areas, and boulevard shaping, grading, compaction and preparation for placement of the specified material.

#### **206.03 Basis for Payment**

This work shall include all labour, equipment and materials to shape the subgrade to the satisfaction of the Contract Administrator.

## **CKSS 209 EMBANKMENTS**

### **REFERENCES**

- OPSS 209 – Construction Specification for Embankments over Swamps and Compressible Soils
- OPSS 501 – Construction Specification for Compacting

### **209.01 Construction**

Earth subgrade materials shall be compacted to a density of 95% Standard Proctor Dry Density.

In no case will the Contractor be permitted to construct the embankment by side dumping.

Embankment construction shall not commence until approved and operative compacting, shaping and watering equipment is on site.

## **CKSS 310 HOT MIX ASPHALT**

### **REFERENCES**

OPSS 310 – Construction Specification for Hot Mix Asphalt  
OPSS 501 – Construction Specification for Compacting  
OPSS 1150 – Material Specification for Hot Mix Asphalt

#### **310.01 Submittals**

At the request of the Contract Administrator the Contractor shall submit a Traffic Management Plan for the provision of access to properties during paving operations. The plan shall be submitted to the Contract Administrator five (5) working days in advance of paving operations.

#### **310.02 Material**

OPSS 310.05.01 is amended to specify the use of reclaimed asphalt pavement (RAP) shall be permitted in binder course only. Up to 20% by mass of RAP shall be permitted in the HL 4 and HL 8 binder mix.

No RAP will be permitted for HL 3, HL 3F HL 4, and HL 4F surface course mixes.

Reclaimed Asphalt Pavement (RAP) and/or Roof Shingle Tabs (RST) are not permitted in any SuperPave or Marshall surface asphalt mixes.

##### **310.02.01 Quality Assurance**

The Contractor shall provide samples of aggregate and asphalt cement to the Owner's authorized material testing company at least three weeks in advance of any paving operations in order to determine a proper asphalt mix design.

The Contractor shall pave a trial batch prior to accepting an asphalt mix design.

##### **310.02.01 Aggregate Gradation and Asphalt Cement Content Acceptance**

Aggregate gradation and asphalt cement content tolerance requirements shall be as per OPSS 310 Table 7.

Acceptance or rejection of HMA according to Table 7 shall be as per OPSS 310.08.04.

#### **310.03 Construction**

The Contractor shall give the Contract Administrator at least 48 hours' notice before commencement of any paving operations or continuation of paving operations after delay of more than five days at the discretion of the Owner or Contract Administrator, in order to ascertain whether the roadway is in the proper condition for paving.

The Owner's standard practice is to leave frames and grates at binder asphalt elevation. When frames and grates have been left at surface asphalt elevation as directed by the Contract Administrator or when the road is being prepared for surface asphalt paving, asphalt padding or ramp shall be placed around all catchbasins maintenance holes, valves, edge of existing pavement and gutter or where directed by the Contract Administrator until the surface course of asphalt is completed.

### **310.03.01 Operational Constraints**

The asphalt binder course shall be laid no earlier than April 15<sup>th</sup>, and no later than November 30<sup>th</sup>, or as directed by the Contract Administrator.

The asphalt surface course shall be laid no earlier than May 1<sup>st</sup>, and no later than October 30<sup>th</sup>, or as directed by the Contract Administrator.

### **310.03.02 Temporary Curbing**

The Contractor shall form temporary asphalt curb around catchbasin lids as per OPSD 601.010 shown on the contract drawings and as directed by the Contract Administrator.

### **310.04 Measurement for Payment**

Hot mix asphalt pricing based on the liquid asphalt cement price index (applies to items paid on a tonnage basis only).

The Owner will adjust the payment to the Contractor based on changes to the Ministry of Transportation's (MTO) PGAC price index (the Contractor will not be permitted to opt out of the adjustment).. The price index will be published monthly in the MTO Contract Bulletin and displayed on the OHMPA ([www.ohmpa.org](http://www.ohmpa.org)) and MTO websites ([www.raqs.mto.gov.on.ca](http://www.raqs.mto.gov.on.ca)). The price index will be used to calculate the amount of the payment adjustment per tonne of new asphalt cement accepted into the Work. The price index will be based on the price, excluding taxes, FOB the depots in the Toronto area, of asphalt cement grade PG 58-28 or equivalent. One index will be used to establish and calculate the payment adjustment for all grades.

A payment adjustment per tonne of new asphalt cement will be established for each month in which paving occurs when the price index for the month differs by more than \$15.00/tonne from the price index for the month prior to tender opening. When the price index differential is less than \$15.00/tonne, there will be no payment adjustment for that month. Payment adjustments due to changes in the price index are independent of any other payment adjustments made to the hot mix tender items. The payment adjustment per tonne will apply to the quantity of new asphalt cement in the hot mix accepted into the Work during the month for which it is established. The payment adjustment for the month will be calculated by the following means:

1. **When AC Prices are Rising** by more than a \$15.00/tonne difference: the payment adjustment to be paid to the Contractor is the result of subtracting the price index for the month prior to tenders closing from the price index in effect when paving took place, minus the \$15.00 float, multiplied by the number of tonnes of PGAC incorporated in the mix(s) as determined by field samples. If the answer is negative, no adjustment is made.
2. **When AC Prices are Falling** by more than \$15.00/tonne difference: the payment adjustment made in favour of the Owner is the result of subtracting the price index in effect when paving took place, plus \$15.00 from the price index for the month prior to tenders closing, multiplied by the number of tonnes of PGAC incorporated in the mix(s) as determined by field samples.

The quantity of new asphalt cement includes all grades of asphalt cement supplied by the Contractor with and without polymer modifiers. For each month in which a payment adjustment has been established, the quantity will be calculated using the hot mix quantity accepted into the Work and its corresponding asphalt cement content as required by the job mix formula except for mixes which contain reclaimed asphalt pavement.

For mixes which contain reclaimed asphalt pavement, the quantity of new asphalt cement will be determined from the difference between the asphalt cement content required by the job mix formula and the asphalt cement content of the reclaimed asphalt pavement incorporated into the hot mix, as calculated by the Contract Administrator.

#### **Example 1 – AC Prices Increasing**

- PGAC 64-28 specified, 3,000 tonnes of HL3 @ 5.0% AC (150.0 tonnes AC)
- Price Index on May 5<sup>th</sup>, 2014 on tender closing is the published April 2014 index \$760/tonne (PG 58-28)
- Price Index on July 17<sup>th</sup>-24<sup>th</sup>, 2014 actual paving dates – \$812/tonne (PG 58-28)
- Payment adjustment to be paid to the Contractor:  
[( $\$812 - \$15$ ) -  $\$760$ ] x 150 tonnes AC =  $\$37$  x 150 tonnes AC =  $\$5,550.00$

#### **Example 2 – AC Prices Decreasing**

- PGAC 58-28 specified, 4,500 tonnes of HL4 @ 5.0% AC (225.0 tonnes AC)
- Price Index on May 5<sup>th</sup>, 2014 on tender closing is the published April 2014 index \$760/tonne (PG 58-28)
- Price Index on October 11<sup>th</sup> – 18<sup>th</sup>, 2014 actual paving dates - \$715/tonne (PG 58-28)
- Payment for hot mix items reduced by:  
[ $\$760 - (\$715 + \$15)$ ] x 225 tonnes AC =  $\$30$  x 225 tonnes AC =  $\$6,750.00$

If the field sample shows that the percentage of AC exceeds the standard specification, then 5.0% shall be used for calculating AC adjustments.

Contractors should bid the hot mix asphalt item using the cost of the PGAC specified. The AC Price Index is only a tool for qualifying hot mix prices and is not intended as a standard AC price to be incorporated into the contract bid.

The payment adjustment calculated using this formula is full compensation for any and all PGAC grades specified.

There will be no AC price adjustment for asphalt placed on a square metre / per metre basis.

If the AC Index has not changed more than \$15.00 per tonne up or down, no adjustment will be applied. Only the amount of the change that is greater than \$15.00 is used to calculate payment adjustments.

Payment for asphalt will be paid at 90% of the unit rate upon placement with the remaining 10% being paid upon receipt of success test results.

### **310.05 Basis for Payment**

Unless otherwise stated in the Contract it is expected that all work will be carried out during week days. However if it is deemed necessary to complete paving operations on weekends and such timing necessitates the Contractor paying over-time premiums for labour beyond that which the Contractor might normally pay, then the Contractor shall account for such extra labour costs in its prices.

Where delays beyond the control of the Contractor have pushed the completion of this work past October 31<sup>st</sup>, the Contractor will be entitled to payment for winter heat.

No additional payment shall be made for the placement, forming, and compaction of an asphalt curb around catchbasin lid.

# **CKSS 311**

## **ASPHALT DRIVEWAY, BOULEVARD, AND MULTI-USE TRAIL**

### **REFERENCES**

OPSS 311 – Asphalt Sidewalk, Driveway, and Boulevard and for Sidewalk Resurfacing

#### **311.01 Construction**

The surface of the asphalt driveway or paved boulevard shall be constructed in such a manner as to give a smooth transition between all new construction and existing driveway or boulevard to remain.

All joints with existing asphalt pavement shall be saw cut.

##### **311.01.01 Pavement Structure**

Unless stated otherwise in the Contract Documents driveways shall be constructed at the following minimum depths (after compaction) according to their listed use.

###### **1. Commercial and Industrial Driveways, High Density Residential**

Granular B	300mm
Granular A	150mm
HL 4	50mm
HL 3	40mm

###### **2. Private Residential Driveways and Paved Boulevards**

Granular A	150mm
HL 3F	50mm

###### **3. Multi-use Asphalt Trails**

Granular A	300mm
HL 4	50mm
HL 3	40mm

This specification refers to Multi-use Asphalt Trails which are to be constructed on the road right-of-way allowance only. For construction of Multi-use Trails on all other locations refer to the City of Kitchener Development Manual.

#### **311.02 Measurement for Payment**

Payment for each item shall be based on the unit of measure listed in the Schedule of Unit Prices.

#### **311.03 Basis for Payment**

Payment for asphalt material will not be processed until all tests have been and received and are deemed acceptable by the Owner.

There will be no separate payment for the saw-cutting of all joints with existing asphalt driveways, boulevards, or trails.

Where delays beyond the control of the Contractor have pushed the completion of this work past October 31<sup>st</sup>, the Contractor will be entitled to payment for winter heat.

## **CKSS 314 UNTREATED GRANULAR, SUBBASE, BASE, SURFACE, SHOULDER, AND STOCKPILING**

### **REFERENCES**

OPSS 314 – Untreated Granular, Subbase, Base, Surface, Shoulder, and Stockpiling

#### **314.01 Construction**

##### **314.01.01 Granular A for Temporary Access**

All Granular A placed shall be on compacted native material or on Granular B as approved by the Contract Administrator and shall be flush with the adjacent existing sidewalk and/or driveway areas. Temporary voids left by sidewalk removal for service installations will be backfilled and shall be included and paid under the appropriate lateral service installation items.

##### **314.01.02 Granular Base Scarify and Reshaping**

Scarifying and reshaping of the granular base shall be required due to the existing asphalt mat being removed and it becomes necessary to redistribute quantities of the existing granular road base to meet the specified roadway profile without adding new granular material.

Following the completion of reshaping the granular roadway surface, the Contractor in the presence of the Contract Administrator shall inspect all structures including sanitary and storm maintenance holes, catchbasins, valve chambers, water valve boxes and gas valves. All debris caused by construction must be immediately cleaned at the Contractor's expense.

#### **314.02 Measurement for Payment**

##### **314.02.01 Granular A for Temporary Access**

Measurement will be by the tonne for walkways and vehicle access areas. Payment at the Contract unit price shall be full compensation for all specified and incidental work required to complete the item to the satisfaction of the Contract Administrator.

##### **314.02.02 Granular Base Scarify and Reshaping**

Payment will be measured by the square metre of area shaped. The Contractor shall notify the Contract Administrator when they intend to complete this work.

#### **314.03 Basis for Payment**

Payment for these items shall include the application of water as required to achieve compaction.

Monitoring and maintenance of the temporary access for pedestrian and vehicular use will be the responsibility of the Contractor and shall be considered to be included in the unit price.

### **314.03.01 Granular A for Temporary Access**

The work of this item shall include all labour, equipment and materials required to provide a neatly trimmed, compacted Granular A surface for a temporary pedestrian access and walkway in sidewalk and access areas disturbed during construction.

In addition, this item shall be for the temporary provision of vehicle access in various driveway and access locations as may be required for temporary movement of vehicles during construction activities.

### **314.03.02 Granular Base Scarify and Reshaping**

Payment of this item to the Contractor shall only be provided when the work is completed with a heavy equipment mechanical grader. Completion of this work with a trim dozer will not be deemed as an acceptable alternative.

## **CKSS 351 CONCRETE SIDEWALKS, DRIVEWAY RAMPS AND DRIVEWAYS**

### **REFERENCES**

OPSS 351 – Concrete Sidewalk  
OPSS 501 – Construction Specification for Compacting  
OPSS 1303 – Material Specification for Admixtures for Concrete

#### **351.01 Material**

Concrete shall be according to OPSS 1350 as amended by CKSS 1350.

##### **351.01.01 Sealant**

Where specified in the Contract Documents sealant shall be Hiac-Plus™ acrylic concrete sealer and Sure-Step™ slip-resistant additive or approved equal.

##### **351.01.02 Nylon Fiber Reinforcement**

Where specified in the Contract Documents Nylon Fiber reinforcement shall be 19mm long mono nylon fiber MULTMESH by Nycon (800-456-9266) or approved equivalent, mixed into the concrete at a rate of 0.6kg/m<sup>3</sup>. Concrete should be mixed for a minimum of five (5) minutes after additive is placed into the mixer to allow for proper distribution of the fiber.

#### **351.02 Construction**

The highest standards and quality of work will be required, and the Contractor's attention is drawn to the clauses on tolerances and curing.

The Contractor shall ensure that the concrete supplier utilizes appropriate aggregates that do not contain deleterious particles that cause concrete popouts. The maximum allowable tolerance for popouts will be 10 popouts per square metre of sidewalk placed. Any sidewalk with popouts greater than this tolerance shall be removed and replaced at the contractor's expense. A popout is defined as a deleterious particle size, a minimum of 13mm wide with a minimum depth of 3mm.

Where the minimum required thickness cannot be achieved, nylon fiber reinforcement shall be added to the concrete mix prior to placement.

##### **351.02.01 Trial Section**

The Contractor shall at the discretion of the Contract Administrator construct a thirty (30) metre trial length to establish the adequacy of its equipment and quality of work.

When coloured concrete is called for in the contract the Contractor shall construct a 0.6m x 0.6m (2ft. x 2ft.) square test patch 30 days prior to the planned construction of coloured concrete throughout the work. This will allow the Owner to verify that the colour palette used for the colouring of the concrete is correct as specified in the Contract Documents.

The adequacy of the Contractor's equipment and quality of work will be determined by the Owner or Contract Administrator on inspection of this trial section of sidewalk or driveway ramp before the Contractor is permitted to proceed with the remaining work.

Should the trial section fail to conform to the specification requirements in any respect, it shall be removed and replaced by the Contractor, at its own expense; otherwise, it shall remain a part of the work.

### **351.02.02 Grading Tolerances**

Grading tolerances shall be as per OPSS 351.07.02.

### **351.02.03 Subgrade for Sidewalk and Driveway Base Preparation**

#### **351.02.03.01 Subgrade**

The subgrade is that portion of the terrain upon which the base is constructed. All soft and spongy sections of the subgrade shall be excavated and filled with approved granular or site generated materials. Materials for fill shall be placed and compacted in 150mm layers.

#### **351.02.03.02 Base**

Thicknesses for Granular Base Course Class "A" shall consist of a minimum of 150mm for residential driveways and 200mm for commercial / industrial driveway entrances, unless noted in the contract documents.

The degree of compaction achieved shall be 100 % Standard Proctor Dry Density.

After completion, the base shall be maintained at its true grade and cross-section until the concrete slab has been placed thereon, and shall be checked for trueness of grade and cross section before the concrete is placed.

Immediately before placing the concrete, the subbase shall be wetted down or alternatively an impervious underlay used to prevent loss of water from the concrete.

### **351.02.04 Formwork**

The forms for curbs, sidewalks and driveway ramps shall be free of warp and other defects and shall be of sufficient strength to resist breaking or bending out of shape. Forms which are not considered acceptable by the Owner or Contract Administrator shall be removed from the site.

Forms shall be firmly staked to the established lines and grades, and the tops of all forms shall conform to the proposed grade of the finished structure. The depth of forms shall be at least equal to the edge thickness of the slab and maintained in good working condition. Forms shall be checked for alignment and elevation before concrete is poured. The Owner or Contract Administrator reserves the right to change formwork as required.

### **351.02.05 Placing Concrete**

The concrete shall be deposited on the base as closely as possible to its final position with a minimum of re-handling. The concrete shall be placed high and screened off with a template riding on the side forms to compress the concrete and bring it to the required elevation and contour. The concrete shall be spaded along the sides of the forms.

### **351.02.06 Thickness**

At intersections the thickness of the concrete sidewalk shall be increased to 200mm from the extension of the end of radius at the curb perpendicular to the back of the sidewalk or to the extent shown on the Contract Drawings and as directed by the Contract Administrator. Concrete at commercial loading areas shall be 200mm thick. Thickness at all other locations shall be as per the City of Kitchener Development Manual.

Where standard thickness cannot be obtained due to obstructions (i.e. tree roots), nylon fiber reinforcement shall be added to the concrete mix.

### **351.02.07 Finish**

Finishes, tooling and saw-cutting shall be done according to RMW Standard Drawing 261. Broom finishes for bus pads, sidewalks, and driveway aprons shall be perpendicular to the roadway.

The finish of connections to private sidewalks or driveways shall conform as closely as possible to that of the existing sidewalk.

After the side forms have been removed, any cavities, honey-combing or other defects shall be repaired.

Trip hazards greater than 10mm will not be accepted. The Contractor should make itself familiar with O. Reg. 239/02 in this regard.

### **351.02.08 Date Imprint**

The Contractor shall install date imprints at intersection ramps and sections of sidewalk repair 7.5 metres or greater in length. The imprint shall include the numerals of the current year into the surface of the sidewalk and shall be not less than 6mm in depth and 75mm in height. No additional compensation shall be given to the Contractor for such imprinting beyond that provided for the construction of the said sidewalk.

For reconstruction projects where an existing street name / date imprint is embedded in the existing sidewalk, the Contractor shall take extreme care to remove the original street name / date stamp and place it in the new sidewalk as directed by the Contract Administrator.

### **351.02.09 Curing**

Immediately after the surface has sufficiently hardened, the sidewalk shall be covered with canvas or burlap and kept moist throughout the period of six consecutive days.

The use of liquid membrane-forming curing compound is also permitted. The compound shall be applied behind the final finishing operation after all free water has disappeared from the surface but not later than one hour after the completion of finishing. The application rate shall be as specified in OPSS 351.07.12.

The application of curing compounds to vertical concrete surfaces shall be required immediately after the removal of forms if such forms are removed within a period of 72 hours from the time of placement of the concrete.

### **351.02.10 Backfilling**

Where an existing sidewalk is repaired, the Contractor shall be required to carefully remove the existing sod and topsoil to enable the forming for the new sidewalk to be installed. This sod and topsoil shall be replaced to the satisfaction of the Owner or Contract Administrator upon removal of the forms. New topsoil and sod may be required as determined by the Owner or Contract Administrator.

In the case of new sidewalks, the edges of the walk shall be backfilled with the surrounding material once the forms are stripped. Such material shall be placed at a 1:1 slope between the surface of the sidewalk and the base.

### **351.02.11 Impressed Concrete**

The installation of impressed concrete shall be carried out by specialist firms engaged in the type of work specified, and using workers skilled and experienced in the various aspects of such work. The Contractor or Subcontractor shall be able to demonstrate proof of ability and examples of impressed concrete installations. Impress concrete using mat forms approved by the Owner or Contract Administrator. Patterns of impression and the direction of forms to be used are to conform to detailed drawings and site directions from the Contract Administrator.

“Double Soldier Course” impressions provided by Proline Concrete Tools or approved equal shall be installed as brick banding behind the back of curb. For wider areas exceeding the width of the band (0.4m), a “Single Soldier Course” shall be provided around the perimeter of the pour with a “Cobble Stone” finish centre, provided by BRICKFORM or Solomon Colours Inc. or approved equal. Ensure all forms are clean and free of any contaminants.

The Contractor is expected to plan concrete pours to ensure impressing operations proceed at the optimum time in the curing schedule for each pour.

Provide a natural finish on the slab surface. The finished slab texture shall be sufficiently coarse for pedestrian and vehicular traffic, as determined by the Owner or Contract Administrator. Where the finished impressed slab surfaces are not acceptably coarse, the Contractor shall sandblast these to the satisfaction of the Owner or Contract Administrator. There will be no additional cost to the Owner for such work. The Contractor shall protect adjacent surfaces from exposure to sandblasting operations.

No steel trowels, steel floats, or power trowels shall be used on the finished surface. The finished impressed slab shall not be modified after removing mat forms prior to concrete set.

Sealants shall be applied to the finished slab. Saw cut finished slab according to detailed drawings and site directions from the Owner or Contract Administrator and according to control joint specifications. Special attention will be paid by the Contract Administrator to the specified tolerances of finished slab grades. Achieve positive drainage and slab tolerances.

#### **351.02.11.01 Mat Forms**

Supply mat forms to achieve the specified paving patterns. All mats shall be subject to the approval of the Landscape Architect. Mats shall be able to achieve a consistent slab surface with no grade variations except for dummy joints. Dummy joints shall produce impressions in the finished slab surface which measure no greater than 6.5mm in width and 6.5mm in depth.

#### **351.02.11.02 Mat Forms Release Agent**

The release agent shall only be an evaporating, non-staining liquid release agent which does not visually modify the finished appearance of the pigmented concrete slab.

### **351.02.12 Shut-Off Valves, Gas Boxes, Etc.**

The Contractor shall adjust to the sidewalk surface all curb boxes, valve chambers and maintenance covers which are located in the walk and free of concrete debris. Care shall be taken to ensure that the extension barrels covering shut-offs are truly vertical. Where new valves or extension sleeves are necessary by reason of a change in grade, they will be supplied and installed by the relevant utility

commission. The horizontal movement of any shut-off valve made necessary by a change in the width of the walk will be attended to by the relevant utilities at no expense to the Contractor.

The cost of adjusting curb stop boxes shall be included in the unit price bid for the sidewalk construction, unless otherwise noted. Valve chamber and maintenance cover adjustments shall be paid for at the unit price bid in the contract Schedule of Unit Prices.

### **351.02.13 Bond Breaker**

A bond breaker shall be placed between the back of curb and adjacent concrete poured against it.

### **351.02.14 Expansion Joints**

Expansion joint material shall be Type "A" bituminous fiberboard, in accordance with OPSS 1308 "Material Specification for Joint Filler (Concrete), manufactured specifically for use in concrete driveway and sidewalk construction.

Expansion joint material shall be a minimum of 9mm to a maximum of 13mm in width and extend the full thickness of the concrete. Alternative materials such as 'Deck-o-foam' (manufactured by W.R.Meadows) or approved equal shall be considered by the Owner or Contract Administrator on a project by project basis.

Expansion joint material shall be cut to the full cross-sectional shape of the sidewalk and placed at the following intervals:

- Every 7<sup>th</sup> panel minimum - 9<sup>th</sup> panel maximum (i.e. - 1.5m panel lengths shall be placed every 10.5m to 13.5m).
- Where the sidewalk section to be replaced is less than 13.5m and greater than 6m in length, place the expansion joints at both ends of the new section.
- Adjacent to rigid structures, including, driveways, foundation walls, retaining walls, utility chambers and vaults and "box-outs" for other surface features, as illustrated in OPSD 310.020, 310.040 and CKDM Std. Dwg. 109

Expansion joint material shall be placed prior to pouring concrete and under no circumstances shall expansion material be forced into freshly poured concrete. Expansion joints shall be neatly cleaned off on both sides of the joint material so that the material is completely visible when finishing is completed. All rubble and imperfections that may affect the contact of expansion joint material with vertical faces, including burrs, gravel, etc. are to be removed prior to placement and pouring of concrete.

Expansion Joints shall be located to minimise the detrimental effects of thermal expansion and to minimise the negative impacts, including risk of trips, due to location and placement, including long term inherent deterioration of expansion material.

### **351.02.15 Contraction Joints**

Contraction joints (for transverse and longitudinal crack control) shall be saw cut to a minimum depth of  $\frac{1}{4}$  of the slab thickness mm. The width of the joint shall be 6mm maximum.

Sawing shall commence as soon as the concrete has hardened sufficiently to permit sawing without excessive raveling, usually within 6 to 24 hours of placement. Joints shall be saw cut day and night, if necessary, in order to prevent uncontrolled shrinkage cracking.

Contraction joints shall be provided using the following spacing and layout guideline:

- Sidewalks (up to 1.8m in width) shall be saw-cut at every panel.

- Wider sidewalks and areas of concrete paving shall be jointed as recommended by the Ready Mixed Concrete Association of Ontario (RMCAO) and the Canadian Portland Cement Association.
- Panel thickness, area of coverage, and location and dimensions of existing features shall all be taken into account in determining jointing details. A jointing detail plan will be required from the contractor, for approval, prior to approval of formwork for placement of concrete.
- Contract Administrator shall approve the layout of all chalk lines and/or provide direction on the Owner's requirements, prior to saw cutting.
- Large concrete paving areas (sidewalk and parking), generally, will not require tooling prior to saw cutting.
- Driveway ramps constructed of concrete may be poured monolithically with adjacent sidewalk, if directed by the Owner or Contract Administrator, to permit a smooth grade transition. Where expansion joints cannot be applied, the edge of sidewalk adjacent to concrete driveway ramps shall be tooled and saw cut to delineate the width of sidewalk area. The inclusion of edge curbs at the sides of residential concrete driveways is no longer a practice of the Owner. The need for side curbs at industrial, commercial and institutional driveway entrances shall be reviewed on a case by case basis.

### **351.02.16 Truncated Dome Detectable Warning Plates**

Truncated dome detectable warning plates shall be installed as per Regional Municipality of Waterloo Standard Specifications RWSS 13 and RMW Standard Drawings 224 to 228.

RMW Standard Drawings 224 to 228 are amended to specify grooved directional lines shall not be used at City of Kitchener owned intersections.

## **351.03 Measurement for Payment**

### **351.03.01 New Sidewalk**

All sidewalks and combined walks shall be measured by the square metre. The reference line for measurement shall be along the centre line of the walk for the purpose of payment.

### **351.03.02 Impressed Concrete**

The unit of measure for this work shall be by the square metre of concrete surface which has been impressed and/or coloured.

### **351.03.03 Truncated Dome Detectable Warning Plates**

The unit of measure for this work shall be for each plate installed as per specifications.

## **351.04 Basis for Payment**

The payment for the unit prices bid for concrete construction shall include the cost of all labour, equipment and materials required to perform the work necessary.

Where delays beyond the control of the Contractor have pushed the completion of this work past October 31<sup>st</sup>, the Contractor will be entitled to payment for winter heat and cold weather protection.

### **351.04.01 New Sidewalk**

The unit price bid for new sidewalk shall be as stipulated in the Schedule of Unit Prices and include normal excavation, expansion and contraction joints as required, application of curing compound and

protection of the concrete from acts of vandalism, and the elements of weather such as extreme heat, cold and rain. Normal excavation is the volume calculated from the finished sidewalk grade to the bottom of the granular material. If additional excavation is required to meet the proposed sub-grade elevation of the sidewalk, the Contractor shall be paid under the appropriate unit price bid in the Schedule of Unit Prices.

In a case where the elevation of the new sidewalk is to be increased, the Contractor shall supply and place the appropriate granular materials as directed by the Contract Administrator. The Contractor shall be paid under the appropriate unit prices bid in the Schedule of Unit Prices.

Supply and placement of specified granular base material will be paid under the appropriate unit prices bid in the Schedule of Unit Prices.

### **351.04.02 Panel Replacement Sidewalk**

Basis for payment as stated below shall apply only where the work is being completed as a separate annual program.

The unit price bid for the replacement sidewalk shall include break-out, removal and disposal of the existing sidewalk as well as restoration of the existing topsoil and sod. New topsoil and sod shall be placed when directed by the Owner or Contract Administrator where the restoration using existing topsoil and sod is unsatisfactory.

In most cases, the existing granular base will be satisfactory and additional granular material will not be required. However, where additional granular material is required, the Contractor shall remove the existing base material as directed by the Owner or Contract Administrator. In this circumstance, the unit price bid shall include the excavation required. Any additional granular material shall be paid under a separate item in the Schedule of Unit Prices.

### **351.04.03 Impressed Concrete**

The work for this item shall include all the labour, equipment, and materials necessary to impress the concrete at locations as shown on the Contract Drawings and as directed by the Contract Administrator.

The price for this item shall also include the cost for the colour pigment admixture, and the concrete sealant.

### **351.04.04 Truncated Dome Detectable Warning Plates**

The work for this item shall include all the labour, equipment, and materials necessary to supply and install truncated dome detectable warning plates at locations as shown on the Contract Drawings and as directed by the Contract Administrator.

## **CKSS 352 CONCRETE STEPS**

### **REFERENCES**

OPSS 1303 – Material Specification for Admixtures for Concrete

#### **352.01 Material**

Concrete shall be according to OPSS 1350 as amended by CKSS 1350.

#### **352.02 Measurement for Payment**

Payment will be made on the basis of the square metre area of the tread, which will include a 30cm wide strip at the top of each set of steps, to construct new steps as outlined in the Schedule of Unit Prices.

#### **352.03 Basis for Payment**

The work for this item shall include all excavation, formwork, base preparation, reinforcing bars, concrete placement, finishing and curing, etc., all in accordance with OPSD 512.011.

Where delays beyond the control of the Contractor have pushed the completion of this work past October 31<sup>st</sup>, the Contractor will be entitled to payment for winter heat and cold weather protection.

## **CKSS 353 CONCRETE CURB AND GUTTER**

### **REFERENCES**

OPSS 353 – Construction Specification for Curb and Gutter  
OPSS 1303 – Material Specification for Admixtures for Concrete

#### **353.01 Material**

Concrete shall be according to OPSS 1350 as amended by CKSS 1350.

#### **353.02 Construction**

##### **353.02.01 Trial Section**

Before proceeding with the curb work under this Contract, the Contractor shall at the discretion of the Contract Administrator construct a thirty (30) metre trial length to establish the adequacy of its equipment and quality of work.

The adequacy of the Contractor's equipment and quality of work will be determined by the Owner or Contract Administrator on inspection of this trial section of curb before the Contractor is permitted to proceed with the remaining work.

Should the trial section fail to conform to the specification requirements in any respect, it shall be removed and replaced by the Contractor, at its own expense, otherwise, it shall remain a part of the work.

##### **353.02.02 Tolerances**

Vertical tolerances for new concrete curbs shall not exceed  $\pm 12$ mm.

A cross-sectional variation of curb and gutter (at any one point) shall not exceed  $\pm 6$ mm.

##### **353.02.03 Bench**

The curb and gutter system shall be constructed with a 50mm bench throughout as per OPSD 600.040, 600.060, 600.080, 600.090, and 600.110. The bench height from the bottom of the curb shall vary due to the various types of curbs to be installed.

##### **353.02.04 Depressed Curb**

In circumstances where intersection ramps are adjacent, the top back portion of the curb shall be depressed 125mm through the entrance and 100mm depressed through driveway entrances. At driveways where concrete sidewalk is curb-faced, the top back portion of the curb shall be depressed 75mm through the entrance. All curbs shall be constructed in accordance with the latest revision of the Ontario Provincial Standard Drawings and City of Kitchener Standard Drawings.

##### **353.02.05 Contraction Joints**

When curb and gutter is placed by the extrusion method, contraction joints shall be formed by saw cutting the hardened concrete within 6 to 24 hours of placing the curb and gutter to prevent uncontrolled cracking. The width of the joint shall be 5mm maximum and the depth 60mm minimum. Maximum

spacing of contraction joints shall be 3.0m. Under no circumstances, shall wet-cut tooled joints be used on machine or hand placed curbs, unless directed by the Contract Administrator.

### **353.02.06 Finish**

Broom finish for the curb is to be perpendicular to the roadway. Top edges of curbing shall be finished with a tool producing a rounded edge of not more than 13mm radius at the inside face.

### **353.02.07 Fish Plates**

Owner supplied metal plates are to be installed in the new curb at all catchbasin grates within the project limits. Fish plates are to be requested by the Contractor at least 48 hours in advance of their planned installation by contacting The City of Kitchener's Stormwater Utility at 519-741-2200 ext. 7355. The fish plates will be available for pick up from The City of Kitchener's Operations Facility at 131 Goodrich Drive.

For placement of the fish plate the Contractor should refer to CKSD 410.010

Wet concrete installation shall be as follows:

- Concrete is to be finished and curing compound applied to the concrete per existing curb specifications. If curing compound is applied after the plate is installed, then the plate is to be protected from the compound using non-marking tape,
- Where a back arch has been installed at a catchbasin the plate shall be offset to either side of the back arch by a minimum of 50cm as directed,
- The plate shall be embedded 3mm into the wet concrete.

### **353.03 Measurement for Payment**

Curbs and combined curbs and gutters shall be measured along the line of the face of curb on curves as well as straight lines.

### **353.04 Basis for Payment**

The unit price bid for curb or curb and gutter construction shall include the excavation required to set the various components to the required line and grade as well as compaction of the base. Normally, the gravel base will be in place and additional gravel should not be required. However, where additional gravel is required, it will be paid for at the unit price bid in the Schedule of Unit Prices.

The unit price bid for curb and gutter construction shall exclude the cost for all adjustments of any appurtenances located within the concrete. Maintenance covers, catchbasins, water and gas valves adjustments shall be paid separately under the appropriate unit prices bid in the Schedule of Unit Prices.

No additional payment will be made for the placement of the fish plates.

Where delays beyond the control of the Contractor have pushed the completion of this work past October 31<sup>st</sup>, the Contractor will be entitled to payment for winter heat and cold weather protection.

## **CKSS 355 INTERLOCKING CONCRETE PAVERS**

### **REFERENCES**

OPSS 355 – Installation of Interlocking Concrete Pavers

#### **355.01 Definitions**

For the purposes of this specification, the following definitions apply:

**unit** means a single precast concrete paver block.

#### **355.02 Material**

The Contractor shall reuse the existing concrete pavers where salvaged and/or supply new ones as necessary to complete the work. New pavers used to supplement the salvaged ones shall be colour matched as closely as possible to the existing pavers.

The Contractor shall consult with the Contract Administrator while colour matching prior to ordering pavers.

##### **355.02.01 Driveway and Walkway Bedding Sand**

Clean, sharp sand free from all debris and organic matter. Sand to be 100% passing the #16 sieve and 10% passing the # 200 sieve.

##### **355.02.02 Permeable Pavers**

Precast pavers for permeable pavement applications shall be ECO-OPTILOC™ by Unilock Ltd. (1-800-864-5625) or Enviro Midori by Oaks Concrete (1-800-709-6257) or approved equivalent.

All permeable concrete pavers shall have spacer bars on each unit.

Pavers shall meet the minimum material and physical properties as per ASTM C 936, Standard Specification for Interlocking Concrete Paving Units and CAN 3-A231.2, Standard Specification for Precast Concrete Pavers.

- The average compressive strength shall be 55 MPa with no individual unit under 50 MPa in accordance with ASTM C396 or CAN3-A231.2-M85.
- The average absorption shall be 5% with no unit greater than 7% when tested according to ASTM C 140.
- The resistance to 50 freeze-thaw cycles, when tested according to ASTM C67 or CAN3-A231.2-M85, with no breakage greater than 1.0% loss in dry weight of any unit. This test method shall be conducted not more than 12 months prior to delivery of units.

Pigment shall conform to ASTM C979.

##### **355.02.03 Access Route Pavers**

Pavers for Access Routes shall be precast Turfstone™ paver units or approved equivalent. Equivalent material shall match the size and shape of the specified product.

#### **355.02.04 Edge Restraints**

Edge restraints shall be Snap Edge® or approved equivalent.

#### **355.03 Construction**

##### **355.03.01 Standard Pavers**

In the event that additional interlocking pavers are required to replace those salvaged from the site which have been damaged after removal, the Contractor shall replace the materials at their own cost.

All work that affects private driveways, walkways, paths and/or patios and like will require the Contractor to cooperate with the property owner(s) and to communicate the extent of the work, timing of impact and reinstatement, and to obtain a satisfactory sign off from the property owner(s) that the work of reinstatement has been completed to the private property owner(s)'s satisfaction.

Granular A shall be compacted to 95% SPDD and leveled to a finished depth of 150mm prior to placement of 25mm of bedding sand and concrete pavers and/or patio stones.

Where concrete pavers abut grass or landscaped/garden areas edge restraints shall be used to prevent lateral movement. The edge restraints shall be secured to the base as per manufacturer's specifications.

The surface of stones shall meet all adjacent walls and curbs flush and at precisely the same grade as adjacent surfaces or as directed by the Contractor Administrator.

All edges of paving stone, where abutting a curb, wall, maintenance hole cover or other material shall have a gap of no greater than 10mm or otherwise specified, between the edge of the paving stone and the abutting material.

After specified stone is laid in specified pattern, spread polymeric sand over surface, brush into joints, then compact. The paving stone shall be compacted with a vibrating plate tamper until the stones are firmly imbedded.

Finished surface shall run true to grade with no bumps or hollows.

##### **355.03.02 Permeable Pavers**

Prior to placement of the pavers the base material shall be inspected and removed of debris or any other foreign material.

The surface of the prepared base shall not deviate more than 10mm from the bottom edge of a 3m straight edge laid in any direction.

Before placement of the bedding aggregate course and the pavers the base shall be inspected by the Contract Administrator.

Pavers shall be free from foreign material prior to placement. Any chipped, damaged or discoloured pavers shall be replaced.

##### **355.03.03 Access Route Pavers**

The work shall include excavation to subgrade, supply, installation and compaction of the 300mm Granular "B" base material, supply, installation and compaction of the 150mm Granular "A" material and application of 75mm of Turfstone™ filled with topsoil and seed.

Sub-grade should be uniformly compacted to at least 95% standard Proctor density prior to placing the gravel, stone and Turfstone™ units.

The sub-base is to be compacted to 98% standard proctor density. The compacted gravel base should extend beyond the edge of the Turfstone™ units a minimum of 6" where possible.

The Turfstone™ units should be placed with the minimum joint spacing of at least 1/16" (2mm). If the Turfstone™ units touch, they may chip and spall upon repetitive loading.

Vibrate the Turfstone™ units using a high-frequency (3500 - 5000 cycles per second), low amplitude plate vibrator. A rubber mat should be attached to the vibrator to protect the grids from cracking and chipping. Plywood sheets placed on the Turfstone™ units can be used for protection if a rubber mat is not available.

The Turfstone™ liner, below the elevation of the permanent pool, voids shall be filled with granular 'A' material. The Turfstone™ maintenance path, above the elevation of the permanent pool, voids shall be filled with topsoil and seeded. The Turfstone™ units should be vibrated until the voids are full. The final level of the gravel should be 1/2" (13mm) to 3/4" (20 mm) below the top surface.

### **355.04 Measurement for Payment**

Payment for this item shall be by the square metre at the unit price quoted in the Schedule of Unit Prices.

### **355.05 Basis for Payment**

#### **355.05.01 Salvaged Pavers**

The work for this item shall include all labour, equipment and materials necessary to install salvaged concrete pavers, including the purchase and supply of additional pavers if required as indicated on the contract drawings to original conditions or better and as directed by the Contract Administrator.

#### **355.05.02 New Pavers**

The work for this item shall include all labour, equipment and materials necessary to install new concrete pavers supplied by the Contractor for placement at locations indicated on the contract drawings and as directed by the Contract Administrator.

## **CKSS 356**

# **PERVIOUS CONCRETE PAVEMENT**

### **REFERENCES**

OPSS 356 – Pervious Concrete Pavement for Low-Volume Traffic Applications

#### **356.01 Submission Requirements**

The Contractor shall provide a detailed work plan and schedule specifically concerned with the successful placement of the pervious concrete. The work plan shall include; sequencing, method of storage of material on site to avoid contamination, method of forming concrete, etc.

The Contractor shall provide samples of aggregate to the Owner's authorized material testing company at least three weeks in advance concrete paving operations.

The Contractor shall provide a mix design to the Owner at least three weeks in advance of pervious concrete paving operations.

#### **356.02 Materials**

##### **356.02.01 Expansion Joints**

Expansion joint material shall be Type "A" bituminous fiberboard, in accordance with OPSS 1308 Material Specification for Joint Filler in Concrete.

Expansion joint material shall be a minimum of 9mm to a maximum of 13mm in width and extend the full thickness of the concrete. Alternative materials such as 'Deck-o-foam' (manufactured by W.R.Meadows) or approved equal shall be considered by the Owner or Contract Administrator on a project by project basis.

##### **356.02.02 Pervious Concrete**

The pervious concrete shall be Hydromedia® by LAFARGE. The pervious concrete may only be placed by approved applicators that have experience with the product. The approved applicator list is as follows and as supplemented by the Contract Documents;

Bevcon Construction and Paving  
416-650-9393

UCC Group Inc.  
416-675-7455

Alliance Site Construction  
416-747-5030

Ro-Buck Contracting  
519-455-1108

- Flexural strength of the concrete shall be 1.5 to 3.0 MPa,
- Slump shall be 150 mm,
- Void content minimum shall be 20%,
- Nominal aggregate size shall be 14mm

### **356.03 Construction**

#### **356.03.01 Preparation**

Prior to placement of pervious concrete, the base material shall be inspected by the Contract Administrator and removed of any debris or any other foreign material by the Contractor.

#### **356.03.02 Placement**

Placement of the concrete shall be continuous and rapid. The Contractor shall avoid overworking the concrete. Do not over vibrate or work the top surface.

#### **356.03.03 Compaction and Finishing**

Pervious concrete shall be compacted with steel roller compactors or vibrating plates to height of the forms. Hand tamping shall be completed near edges and other places not reached. Compaction shall be completed within 15 minutes of placement. The Contractor shall not float or trowel the concrete. Minimize over working or movement of the surface after compaction, this includes walking on the surface.

#### **356.03.04 Curing and Protection**

Fog mist the surface of the concrete within 20 minutes of compaction. Cover the concrete with thin plastic sheeting within 20 minutes after placement and leave in place for 7 days. Additive curing compounds may be used as specified in the Contract Documents.

### **356.04 Measurement for Payment**

The measurement for payment shall be by the square metre of pervious concrete poured. The Contractor shall receive 50% of the total value upon placement of the pervious concrete. The remaining 50% will be paid upon receipt of satisfactory QA/QC test results by the Owner's authorized material testing company and from the Contractor's Material supplier.

### **356.05 Basis for Payment**

The Contractor shall include in its unit price for this item the equipment, labour and materials required to pour and place the pervious concrete at the location and to the dimensions as shown on the Contract Drawings and as directed by the Contract Administrator. The Contractor's price shall also include all required Quality Control and Quality Assurance tests. The Contractor will ensure a representative from the manufacturer is on-site to witness the pervious concrete placement. Payment shall include supply, placement and removal of a temporary tarp on top of the pervious concrete as necessary (to prevent contamination of the concrete and granular base) for light construction vehicle access during restoration activities.

## **CKSS 401 TRENCHING, BACKFILLING, AND COMPACTING**

### **REFERENCES**

OPSS 401 – Trenching, Backfilling, and Compacting  
DGSSMS

#### **401.01 Construction**

##### **401.01.01. Bedding**

Unless otherwise specified in the Contract Documents all bedding shall be Class "B". Material for pipe bedding shall meet the requirements as specified in DGSSMS and OPSS 401.

##### **401.01.02. Backfill**

If, in the opinion of the Contract Administrator, the excavated material is unsuitable for use as backfill, (i.e. - if the Contractor cannot attain the minimum required degree of compaction using the excavated material as backfill), the Contractor shall be directed by the Contract Administrator (in writing) to either use appropriate site generated material or import fill as per the recommendation of the Geotechnical Consultant.

Backfilling of trenches shall be kept within 15 metres of pipe laying unless by permission or instruction of the Contract Administrator. At the end of each workday the trench shall be backfilled.

#### **401.02 Measurement for Payment**

With the exception of material used for infiltration trenches, payment shall be included in the unit price of the sewer, watermain, forcemain, and culvert.

#### **401.03 Basis for Payment**

The costs for sub-excavating and disposal of the unsuitable subsurface material shall be paid according to the rates as specified in the Schedule of Unit Prices.

The work of this item shall include all labour, equipment and materials required to supply, place and compact suitable backfill of unspecified depth in areas specified by the Contract Administrator including grading and compaction, all in accordance with OPSS 401, except as extended or amended herein.

No payment shall be made for normal trenching to required subgrade elevations, for servicing (storm and sanitary sewers, watermain, culverts, forcemains, etc.). No payment shall be made for backfill and compacting with suitable excavated material.

## **CKSS 405 PIPE SUBDRAINS**

### **REFERENCES**

OPSS 405 – Pipe Subdrains  
OPSD 216.021  
DGSSMS

#### **405.01 Material**

Subdrains shall be 150mm corrugated high-density polyethylene 210 kPa tubing, perforated with geotextile sock filter. As per OPSD 216.021 the first 1m from the point of connection at the structure shall be non-perforated.

##### **405.01.01 Bedding and Backfill**

Bedding and backfill material shall be concrete sand meeting the gradation requirements of OPSS 1002 (Fine Aggregate for Concrete).

#### **405.02 Construction**

Subdrains shall be installed on the upstream side of catchbasins as per the City of Kitchener Development Manual and/or as directed by the Contract Administrator.

#### **405.03 Basis for Payment**

The work of this item shall include all labour, materials and equipment required to install and connect to catchbasins and catchbasin maintenance hole 150mm dia. subdrains in locations shown on the contract drawings, including specified bedding and backfill material as per OPSD 216.021.

## **CKSS 407 MAINTENANCE HOLE, CATCHBASIN, DITCH INLET AND VALVE CHAMBER INSTALLATION**

### **REFERENCES**

OPSS 407 – Maintenance Hole, Catchbasin, Ditch Inlet, and Valve Chamber Installation  
DGSSMS

#### **407.01 Material**

##### **407.01.01 Precast Structures**

Precast maintenance holes for use with exfiltration pipes shall be a minimum of 1500mm nominal inside diameter unless otherwise specified.

##### **407.01.02 Round PVC Drain Basins**

In grassed areas with no traffic loading, Drain Basins shall be Nyloplast Drainbasin by ADS or approved equivalent.

If the maintenance hole is to be placed in a traffic loading area Chief Municipal Approval is required. Concrete collar shall be provided as per manufacturer's specification.

##### **407.01.03 Catchbasin Quality Control Device**

Quality control devices for catchbasins shall be CB Shield™ quality device by CB Shield Inc. (519-212-9161) as per CKSS 1851 and manufacturer's specifications.

##### **407.01.04 Hydrodynamic Separator**

The hydrodynamic separator shall be certified as per the Canadian ETV Program General Verification Protocol (May 2013), where testing has been conducted by an independent 3rd party technology performance testing laboratory. Sediment scour and re-suspension performance testing and light liquid re-entrainment testing demonstrating that light liquids are captured after a spill are effectively retained during high flow rates must be included.

Hydrodynamic separator make and model shall be as shown on the contract drawings or as specified elsewhere in the Contract Documents.

No internal component shall be modified or replaced.

The Contractor shall ensure that the hydrodynamic separator unit supplied and installed perform to a level sufficient to removing the particle size distribution expected from the City of Kitchener as approved by the Agency.

The hydrodynamic separator shall be precast concrete, with inert materials used for internal component parts.

The separator shall remove sediment from storm water during frequent wet weather events, downstream to high flow bypass to prevent scouring. The separator shall treat a minimum of 90 per cent of the annual runoff volume and shall be capable of removing 80 per cent of the total suspended sediment load. The

separator must be capable of trapping silt and clay size particles from runoff based on the ETV Canada specified PSD.

The hydrodynamic separator shall be installed underground as part of the storm sewer system and shall be structurally designed for Canadian Highway Bridge Design Code (CHBDC) traffic loading at the surface. The storage in the separator shall be vertically oriented. The separator shall be maintainable from the surface via one access point without requiring entry into the separator.

## **407.02 Construction**

### **407.02.01 Precast Structures**

All maintenance holes, including catchbasin maintenance holes to be benched regardless of sewer main pipe size as per OPSD 701.021. Benching shall be three quarters of the diameter of the largest pipe.

Diversion maintenance holes which include an internal weir and/or orifice plate shall not be benched.

Special maintenance hole structures shall be constructed according to the details shown on the contract drawings.

Unless otherwise noted on the contract drawings all frames and covers set in asphalt curb shall be set to base asphalt elevation as shown on the contract drawings. All frames and covers set in sodden, top-soiled or landscaped areas shall be set to finished grade elevation.

### **407.02.02 Connection to Existing**

In the case of existing maintenance holes, the connection shall be deemed to include all maintenance hole reconstruction and re-benching, and pipe of the same material as the existing pipe (as allowed in DGSSMS) up to 4m in length required to make the connection from existing pipe to proposed structures.

### **407.02.03 Catchbasin Quality Control Device**

Quality control devices shall be installed as soon as catchbasins are connected to the storm sewer main system to prevent clogging of LID facilities.

## **407.03 Measurement for Payment**

### **407.03.01 Catchbasin Quality Control Device**

Measurement for payment of this item shall be for each device installed by the Contractor.

### **407.03.02 Hydrodynamic Separator**

Measurement for payment of this item shall be for each hydrodynamic separator device regardless of the depth.

## **407.04 Basis for Payment**

### **407.04.01 Precast Structures**

The cost to supply and install new maintenance holes and catchbasin frames and covers with adjustment units are **not** to be included in these unit prices and will be paid for separately. The cost to construct drop structures and install safety platforms shall be included in this item when shown on the Contract Drawings.

#### **407.04.02 Catchbasin Quality Control Device**

The price for this item shall be for all equipment, labour and materials required to supply and install the specified quality control device at locations specified in the contract documents and/or the approved contract drawings.

#### **407.04.03 Hydrodynamic Separator**

The price for this item shall be for all labour, equipment and materials required to supply and install the hydrodynamic separator including all internal components at locations shown on the contract drawings. The cost to supply and install frames and covers with adjustment units shall be included in the unit price of this item.

#### **407.04.04 Connection to Existing**

The price for this item shall be for all labour, equipment and materials required to connect the existing sewer system to the proposed sewer system as shown on the contract drawings and as directed by the Contract Administrator.

## **CKSS 408**

### **ADJUSTMENT OF FRAMES AND COVERS**

#### **REFERENCES**

OPSS 408 – Adjusting or Rebuilding Maintenance Holes, Catch Basins, Ditch Inlets, and Valve Chambers

OPSD 704.010 – Precast Concrete Adjustment Units for Maintenance Holes, Catch Basins, and Valve Chambers

#### **408.01 Construction**

The Contractor shall adjust to the finished grade of the road or boulevard or whatever finished grade is applicable, frame and cover for all chambers, maintenance holes, catchbasins, valve boxes, water service boxes, gas valves, and other items required to be raised to finish grade. Access to water valves and gas valves shall be maintained at all times.

#### **408.02 Measurement for Payment**

Measurement for payment will be on an each basis for adjustments and payment at the Contract unit price and shall be full compensation for all specified and incidental work required to complete the item of work to the satisfaction of the Contract Administrator.

#### **408.03 Basis for Payment**

The work of this item shall include all labour, material and equipment required to adjust existing features as outlined in CKSS 408.01 to meet the final grades of boulevards, sidewalks, roadways or other finished areas, including excavation, removal of existing brickwork as applicable, supply and installation of precast/pre-manufactured adjustment units, parging, backfilling and compaction to 100% SPDD all in accordance with OPSS 501, except as extended or amended herein.

## **CKSS 409 CCTV SURVEY AND MANDREL TESTING OF SEWERS**

### **REFERENCES**

OPSS 409 – Closed-Circuit Television Inspection of Pipelines  
DGSSMS

#### **409.01 Construction**

##### **409.01.01 Pipeline Cleaning**

The Contractor will flush and clean sewers, maintenance holes, and catchbasins, prior to testing and inspection. Testing shall be done in the presence of the Contract Administrator. The Contractor shall supply all water for cleaning and testing.

##### **409.01.02 CCTV Inspection**

All testing and inspection shall be completed after the placement of the base course of asphalt.

Inspection of the service laterals shall be from the main line connection to at least five (5) metres past the connection to the existing service. Inspection of all existing and constructed service laterals shall be video recorded.

Inspection of first downstream sewer main pipe segments, outside of project limits, shall be video recorded to ensure no migration of construction debris.

#### **409.02 Final Documentation**

The Contractor shall supply a hard copy report (with a map) and three (3) copies of a new DVD video record of all observations summarizing the CCTV Inspection to WRc standards.

#### **409.03 Quality Assurance**

A mandrel test shall be performed on all flexible pipes in accordance with OPSS 410 of which deflection of no more than 7.5% (CSA 182.11) of the nominal inside diameter will be deemed an acceptable installation. The test shall be completed on the sewers after the base asphalt has been laid. All maintenance holes, and catchbasins shall be inspected for defects and signs of leakage. Repair visible leaks or faults as approved by or as directed by the Contract Administrator.

No part of the work will be accepted until the sewers are clean and free from sand, earth, mud or other obstructions.

Any breaks, leakages, or other deficiencies found in the sewer system shall be repaired at the Contractor's expense.

If in the opinion of the Owner, re-inspection is required as a result of inadequate cleaning or any other deficiencies, the Contractor shall re-clean or make good all required repairs and re-inspect the sewer at no additional cost to the Owner. The Owner shall undertake at its cost, a final inspection of the sewers prior to the end of the two (2) year maintenance period. Any and all required deficiencies shall be the responsibility of the Contractor and shall be rectified by the Contractor prior to the Owner's final acceptance.

Final acceptance of the sewer system will not be granted until the inspection report and related data have been received and accepted by the Owner and all deficiencies corrected to the satisfaction of the Owner.

**409.04 Measurement for Payment**

The compensation at the set unit price shall be paid per lineal metre of sewer main or service lateral inspected and tested.

**409.05 Basis for Payment**

The unit price bid shall include all labour, equipment and materials to complete the work. Incomplete or non-compliant submissions returned for correction shall be corrected and resubmitted at no expense to the Owner.

## **CKSS 410 PIPE SEWER INSTALLATION**

### **REFERENCES**

OPSS 410 – Pipe Sewer Installation in Open Cut  
DGSSMS

#### **410.01 General**

##### **410.01.01 Service Laterals**

The location of all existing service laterals is based where possible, on historic records and CCTV inspection. In some cases, the records of status and location of existing sanitary laterals and cellar drain connections may be incomplete. As a result, the exact location of laterals and drains will be determined at the time of installation. Both the sanitary lateral and the cellar drain (where present) shall be connected to the new main. It is the responsibility of the Contractor to investigate all lateral connections encountered while replacing sanitary and other sewers.

#### **410.02 Material**

##### **410.02.01 Sewer Main**

In addition to the requirements of DGSSMS C.3.1.7 Profile HDPE pipe shall have integral bells.

##### **410.02.02 Exfiltration Pipe**

The pipe material shall be PVC with a smooth wall interior and a minimum diameter of 200mm. The pipe shall meet the requirements of OPSS 1841, and CSA B182.2. All piping shall use manufacturer and Owner approved couplings and fittings. Connections between the perforated and non-perforated sections shall be made with Owner approved fittings.

Perforated sections of storm sewer shall come with manufacturer installed perforations. On-site perforations of solid pipe sections shall not be considered equivalent perforated pipe and will not be accepted.

As a minimum, all pipes shall be marked to designate the pipe manufacturer, pipe class, and Manufacturer's Quality Assurance Stamp. Each fitting shall be marked to indicate its position in the pipeline.

No substitutions shall be accepted. In cases where the material is not available the Contractor shall review options with the Contract Administrator for approval by the Owner.

##### **410.02.03 Service Laterals**

For trenchless installations service pipe shall be HDPE-DR17 pipe with no more than one butt fused joint per service. The connection at property line for a trenchless HDPE installed service shall be completed using a 200mm long Fernco Inc. shielded coupler model number 1056-442RC with shield model number SRC-01-XL or approved equivalent.

#### **410.02.04 Filter Sock**

Filter sock shall meet the requirements of ASTM D6707 type A fabric.

#### **410.02.05 Casing Pipe**

Casing pipe shall be PVC DR-28 and a minimum of 100mm diameter. Where casing pipe needs to be larger based on the carrier pipe the casing pipe shall be a minimum of two (2) nominal pipe sizes larger.

### **410.03 Construction**

#### **410.03.01 Maintenance of Sewage Flows**

In addition to the requirements of the Region of Waterloo's Sewer Use By-Law 21-036, and the Environmental Protection Act (O. Reg. 347/90), the Contractor will not be permitted to pump sanitary sewers outside of normal working hours (unless approved by the Owner), in the event there are pumping failures. The Contractor shall provide temporary, watertight, PVC, main reconnections at the end of each day's construction activities.

In addition, all service laterals exposed and intercepted shall be connected to the new main. Temporary service reconnections shall be watertight PVC connections. At no time will raw sewage be permitted to stand in open trenches.

The Contractor shall be required to provide for (Silent) pumps and generators to accommodate for a range of flow rates.

Upon request estimated flows can be obtained from the Contract Administrator.

#### **410.03.02 Locate Existing Service Lateral**

The Contractor shall investigate all existing lateral service pipes as shown on the Contract Drawings and as they are exposed in the roadway while installing the new sewer main.

Wherever possible the Contractor shall use dye tracing as the default method to determine sewer connection origin. However, when dye tracing is unsuccessful the Contractor is to either insert a plumber's fish tape into this service pipe and connect thereto the electronic pipe and cable locator tracing wire or complete a closed-circuit television inspection of the existing service lateral.

For services to be replaced by a method of trenchless excavation the Contractor shall supply a copy of the CCTV record of each existing service to the Contract Administrator two (2) weeks before the proposed service is to be installed.

This method of locating existing service laterals will be as directed by the Contract Administrator and undertaken when an exact location is required prior to excavating at the property line by the Hydrovac or mini-excavator method.

The Contractor shall use this method to identify the exact location of laterals and drains as necessary to ensure reconnection of all live systems.

### **410.03.03 Sewer Main Installation**

Rubber gasket joints shall be used for horizontal elliptical concrete pipe where manufactured sizes allow. Mortar joints are to be as per ASTM C507.

The use of "Lox Seal" Sewer compound as supplied by National Coupling Limited, or approved equivalent may be considered by the Owner.

### **410.03.04 Exfiltration Pipe**

Perforated piping shall not be used to make connections with maintenance hole or catchbasins within 2m of the storm structure. Perforated pipe shall not be used through clay seal/plug sections.

Perforated piping shall transition to the solid pipe sections as per CKSD 821.012. Transitions shall be made inside of the infiltration systems.

Ensure pipe interior and coupling surfaces are clean before laying the pipes. Do not use any type of shim to establish pipe slope. The exfiltration pipes shall be properly sloped and lead to a permanent positive outlet in accordance with connection details.

Filter sock shall be installed from end to end of pipe terminating at the maintenance hole structure. A minimum overlap of 500mm shall be provided.

As soon as the exfiltration pipes are connected to the maintenance hole the Contractor shall install the plugs to prevent the introduction of sediment contamination during construction.

### **410.03.05 Service Lateral Installation**

Using the CCTV record the Contractor shall choose the appropriate method of trenchless replacement for a service lateral so as not to replicate a defect in the existing pipe (i.e. sag in service). The Contractor shall submit in writing their proposed method of trenchless replacement prior to completion of each service to be replaced.

When connecting a new 100mm diameter pipe to an existing 150mm diameter pipe, an eccentric adapter shall be used to provide a uniform transition at the inverts of these pipes. The possibility may arise where both the cellar drain and sanitary can be combined into one sound connection, with the use of proper wye connections, adaptors, reducers, etc. Where combined sewer connections are warranted, only one payment for the connection will apply, as per the appropriate tender item.

The trenchless method shall create an opening for the 100mm dia. sanitary service pipe, and (if required) a 25mm dia. water service pipe installation in the same tunnel.

Hydrovac excavations at the property line or as directed by the Contract Administrator should be completed to facilitate the reconnection of the service pipe. The Contractor may be allowed to excavate for the tunnel access pits at the property line with the use of a mini-excavator in lieu of the Hydrovac method, provided that the maximum trench opening at the surface does not exceed 2.0m X 2.0m.

Bedding and cover material on a trenchless services lateral at property line shall be 19mm clear stone.

If any of the additional existing service laterals are found to be connected to sump pumps, surface drains or to foundation weeping tiles, these connections are to be connected to the storm sewer system. If any connections are found to be combined sanitary, eaves trough and foundation weeping tile drains, the source of stormwater and/or groundwater entering into the these connections are to be disconnected from

the sanitary sewer system and re-plumbed for connection to the storm sewer system or discharged to grade.

The Contractor shall inspect each service lateral using CCTV after the connection to the existing service has been completed.

#### **410.03.06 Joint Restraint Inside Casing**

For sewer main and service lateral from 100mm to 300mm diameter the Cobra Lock™ System by Royal Pipe Systems (or approved equivalent) shall be used on all joints contained inside of the casing limits and up to three (3) metres outside from the end of the casing.

#### **410.03.07 Connect to Existing**

The Contractor shall construct all connections to join the work to existing services.

When a connection is to be made, the Contractor shall expose the end of the existing service or main for inspection by the Contract Administrator. All connections are to be watertight.

When connecting a new main to an existing maintenance hole the Contractor shall install a resilient connector in the structure as per manufacturer's specifications and contract drawings.

#### **410.03.08 Filter Sock**

The filter sock shall be installed from end to end of pipe terminating at the maintenance hole structure. A minimum overlap of 500mm shall be provided.

### **410.04 Measurement for Payment**

#### **410.04.01 Maintenance of Sewage Flows**

Payment will be made on a percentage completed basis to complete all work.

#### **410.04.02 Sewer Main Installation**

Payment will be made on a prorated basis with ninety (90) percent being paid on completion of the appropriate section, with the remaining ten (10) percent being paid upon acceptance by the Owner of all testing.

#### **410.04.03 Exfiltration Pipe**

Payment will be made on a prorated basis with ninety (90) percent being paid on completion of the appropriate section, with the remaining ten (10) percent being paid upon acceptance by the Owner of all testing. The per metre rate shall be measured from centre of maintenance hole to maintenance hole.

#### **410.04.04 Service Lateral Installation**

Individual service lateral installation, with all necessary adaptors, reducers, etc., will be paid for on an each basis as outlined in the Schedule of Unit Prices.

## **410.05 Basis for Payment**

### **410.05.01 Exfiltration Pipe**

The price for this item shall be for all equipment, labour, and materials to install perforated pipe and solid wall pipe in an exfiltration trench system, including all connections to storm structures, caps and couplers. The price per metre shall be for both exfiltration pipes from maintenance hole to maintenance hole. The cost for this work shall also include the supply and installation of the filter sock.

No additional payment shall be made for the supply and installation of permanent and temporary plugs at each end of the exfiltration pipe. The Contractor shall remove the temporary plug at their own cost.

### **410.05.02 Service Lateral Installation**

Unless otherwise provided in the Schedule of Unit Prices, no additional payment shall be made to reconnect a service lateral to the existing service. The Contractor is responsible to allow for excavation, bedding, pipe installation, cover, and backfill a minimum of one (1) metre past the limit of the right-of-way.

The price for the trenchless items shall include review of the video inspection record to determine the appropriate method of replacement.

No payment will be made for the trenchless items listed in the Schedule of Unit Prices if the Contract Administrator has not received the Contractor's proposal for trenchless method of replacement.

### **410.05.03 Locate Existing Service Lateral**

The work of this item shall include all labour, equipment and materials required to locate existing sanitary, cellar drain and storm service pipes, by using an electronic pipe and cable locator, a plumber's fish tape, or CCTV video survey.

### **410.05.04 Connection to Existing**

No claim by the Contractor shall be allowed for any delays due to changes in design which may be required due to the revealed conditions.

The work to connect proposed sewers to existing maintenance holes and catchbasin maintenance holes shall include the cost to re-bench the structure and bulkhead / plug abandoned inlet / outlet pipes at the structure, installation of a resilient connector or brick, parging as required, and any additional pipe required to make the connection from existing structure to proposed pipes.

### **410.05.05 Casing Pipe**

Where Casing pipe is required for the installation of service connections through LID stormwater facilities the work for this item shall also include the supply and installation of spacers, joint restraints and end seals.

## **CKSS 416 PIPELINE INSTALLATION BY JACKING AND BORING**

### **REFERENCES**

OPSS 416 – Pipeline and Utility Installation by Jacking & Boring

#### **416.01 Definitions**

For the purpose of this specification, the following definitions apply:

**Casing Pipe** is the pipe which houses the carrier pipe.

#### **416.02 Basis for Payment**

The unit price shall include the supply of all equipment, labour and materials necessary to install a steel casing to the diameter, wall thickness, length, and method as shown on the Contract Drawings and as indicated on the Schedule of Unit Prices. The work for this item shall also include installation of spacers, joint restraints, end seals, welding, and anodes as per manufacturer's instructions.

## **CKSS 441 WATERMAIN INSTALLATION**

### **REFERENCES**

OPSS 441 – Watermain Installation in Open Cut  
DGSSMS

#### **441.01 Material**

##### **441.01.01 Valve Nut Extensions**

Where required water valve nut extensions shall be Assembled Valve Stem Extensions by Bren Technologies Inc. (120 Walker Drive, Brampton, Ontario, Tel. 905-951-8118 or 1-888-688-2047) or approved equivalent.

##### **441.01.02 Hydrants**

Hydrants shall be greased by the manufacturer prior to being delivered to the site.

##### **441.01.03 Valve Boxes**

The City of Kitchener will only accept outside set screw type valve boxes.

#### **441.02 Construction**

##### **441.02.01 Joint Restraint Inside Casing**

For water main and service connections from 100mm to 300mm diameter the Cobra Lock™ System by Royal Pipe Systems (or approved equivalent) shall be used on all joints contained inside of the casing limits and up to three (3) metres outside from the end of the casing.

##### **441.02.02 Connect to Existing**

The Contractor shall be required to expose the existing watermain at the points of connection to determine the exact depth and location, so that the proper fittings can be pre-arranged for connection at a later date. New watermains shall not be connected to the existing watermains until they have been pressure tested, chlorinated, flushed, bacteriological tested and accepted by the Owner.

##### **441.02.03 Services**

The location records for existing water service laterals may be incomplete. The exact location of the service will be determined at the time of construction.

The Contractor will be permitted to deviate from straight-line installations to avoid disruption to trees/roots, etc. Hand excavation should be expected and will be required to avoid tree root damage. The Contractor shall install the new service from the point of connection at the main to the existing service at/or beyond the property line. All curb stop valves, main stops and service boxes will be replaced with new ones. The Contractor will be required to furnish all fittings needed to connect to the existing service regardless of its size, type and/or condition.

The Contractor shall supply and install a 12 lbs. anode attached to the private side metallic service.

#### **441.02.03.01 Services Left in Place**

Where an existing copper water service is found to be in good condition and means of its replacement may be deemed to be difficult due to above ground conflicts, Kitchener Utilities (KU) is to inspect the service to verify its condition. If KU deems that the service does not need to be replaced, then the Contractor shall join to the existing service with same material as well as placement of an anode. For existing polyethylene pipe stiffeners (one on each side) and a 'Philmac' compression fitting or approved equivalent as per manufacturer's specification shall be installed.

#### **441.02.03.02 Live Service Connection Tapping**

Tapping of live mains are to be completed by Kitchener Utilities only. The Contractor will not be permitted to complete live main taps. The Contractor shall give Kitchener Utilities five (5) working days' notice for live tapping requests. Tapping requests should be made for after 9:00 am or later where possible.

#### **441.02.04 Service Connection Pit**

The Contractor shall backfill the service pit immediately after installation of the service pipe and hydro-vac excavate at final connection. The use of temporary orange plastic construction fencing shall not be considered an acceptable method of maintaining a safe open pit. Options for maintaining a safe open pit during the work day available to the contractor are as follows:

- Temporary chain link construction fencing i.e. fast fence or approved equivalent,
- Metal plate covering with caisson.

All excavations shall be backfilled prior to the end of the work day unless permitted by the Contract Administrator.

#### **441.03 Measurement for Payment**

##### **441.03.01 Live Service Connection Tapping**

The Contractor shall be charged for stand-by time if the tapping area is not ready for Kitchener-Utilities to complete their work.

#### **441.04 Basis for Payment**

##### **441.04.01 Watermain**

The unit price bid shall include all labour, equipment and materials, including all bends, fittings, adaptors, tees, crosses, joint restraints, restraining glands, thrust blocks, tracer wire, anode, etc., to complete the work.

##### **441.04.02 Connect to Existing**

The price for this item shall include all labour, equipment and materials to connect to the existing water supply system. The work shall also include the exposure of the existing watermain at the points of connection to the new watermain prior to proposed installation as directed by the Contract Administrator.

### **441.04.03 Valves**

The unit price bid shall include all labour, equipment and materials, including all restraining glands, thrust blocks, tracer wire, etc., to complete the work. The price for this item shall also include water valve nut extensions when they are required.

### **441.04.04 Services**

The price for this item shall include supply of all labour (including hand digging around tree roots), equipment and materials to complete the work in accordance with Region of Waterloo SSMS Standard Drawings. The Contractor is responsible to allow for excavation, bedding, pipe installation, cover, and backfill a minimum of one (1) metre past the limit of the right-of-way. The connection of an anode to the existing metallic service on private property shall be included in the price for this item.

The Contractor shall include in their unit price for water services the cost to maintain a safe service connection pit.

## **CKSS 442**

# **CORROSION PROTECTION OF WATERMAINS**

### **REFERENCES**

DGSSMS  
CKSD 1104.010

#### **442.01 Construction**

If the existing watermain is non-metallic, connect the new tracing wire to the existing tracing wire by using a copper split bolt wrapped with dielectric tape as per DGSSMS.

If the existing watermain is metallic, the tracing wire shall not under any circumstances be connected to the existing main or to metallic fittings or valves connected to the existing metallic main.

Installation of corrosion protection for metallic fittings shall be as per the DGSSMS.

##### **442.01.01 Water Services**

Corrosion protection for water services shall be as per CKSD 1104.010.

#### **442.02 Measurement for Payment**

Payment will be per each metallic fitting completed.

#### **442.03 Basis for Payment**

The payment for this item shall include all labour, equipment, and materials necessary to complete the work as described in the specifications.

## **CKSS 480 EXFILTRATION TRENCH SYSTEMS**

### **REFERENCES**

OPSS 410 – Pipe Sewer Installation in Open Cut  
CKSS 410 – Pipe Sewer Installation

#### **480.01 Submission Requirements**

The Contractor shall provide a detailed work plan and schedule specifically concerned with the successful construction of the Infiltration System. The work plan shall include the following minimum details; sequencing, material source suppliers, method of storage of material on site to avoid contamination, method of avoiding contamination of the facility during construction, etc.

#### **480.02 Material**

##### **480.02.01 Geotextile**

Woven geotextile shall be TenCate Mirafi® RS380i or approved equivalent or as specified in the Contract Documents.

Woven or non-woven geotextiles shall be as per CKSS 1860 and OPSS 1860.

##### **480.02.02 Seals**

Seals may be either bentonite clay or low strength concrete unshrinkable fill as per CKSS 564.

#### **480.03 Construction**

##### **480.03.01 Preparation**

Execute excavating trench ensuring bottom and sides of excavation have been scarified and non-compacted (compacted for sections within roadway). Do not place clear stone bedding material prior to approval of excavation by Contract Administrator.

Care shall be exercised to prevent natural or fill soils from intermixing with the clear stone. All contaminated stone shall be removed and replaced with uncontaminated stone at the Contractor's own expense.

##### **480.03.02 Erosion and Sediment Control**

Areas designated for infiltration facilities should never serve as a sediment control device during construction. Construction runoff should be directed away from the proposed facility location. Upstream drainage from all sources should be intercepted with a temporary sediment control device as shown on the Contract Drawings and as directed by the Contract Administrator.

After the site is vegetated, temporary erosion and sediment control devices can be removed and the system brought online.

### **480.03.03 Seals**

Seals shall be as per OPSD 802.095 to be used between each infiltration system and as specified on the Contract Drawings and as directed by the Contract Administrator.

### **480.03.04 Geotextile**

Wrap excess geotextile overtop of aggregate used to cover the perforated pipe such that folds overlap by a min of 0.5m within the centre of the trench in order to provide separation between native and granular backfill and clear stone.

Solid pipe connections such as lead tie-ins or transitions from perforated to solid pipe sections which need to pass through the geotextile shall be established by creating and "X" in the geotextile and feeding the solid through the geotextile. The triangular folds of the "X" shall point away from the infiltration system and toward the source of the solid pipe sections and shall be secured to the outside of the solid pipe using zip ties. The Contractor shall ensure that no granular backfill used for the solid pipe sections shall be able to migrate and contaminate the open graded aggregate of the infiltration system. Should additional geotextile be required to ensure this requirement is met, additional geotextile pieces shall be provided at the Contractor's own expense.

## **480.04 Measurement for Payment**

### **480.04.01 Geotextile**

Payment for this item shall be per square metre of geotextile supplied and installed as part of an infiltration system.

## **480.05 Basis for Payment**

### **480.05.01 Geotextile**

The price for this item shall include all labour, equipment and materials required to supply and install geotextile wrap as part of an infiltration facility. The Contractor shall include in their price the work required to modify the geotextile based on site specific conditions as shown on the Contract Drawings and as directed by the Contract Administrator.

## **CKSS 481 OBSERVATION PORTS FOR INFILTRATION SYSTEMS**

### **REFERENCES**

CKSD 820.010 – Observation Port for Stormwater Management LID

#### **481.01 Material**

The observation port cap shall be a 6 Inch Cleanout cover (150mm) inside diameter by DomCast Components & Assemblies or approved equivalent.

Observation port caps shall have an H-20 traffic rating, a water resistant seal and a means of locking the cover.

The observation port standpipe shall be 150mm diameter PVC DR-11.

#### **481.02 Construction**

The observation port cap shall be fitted into the stand pipe collar extending from the surface through the profile of the infiltration facility. The observation port stand pipe collar shall be embedded in gravel filled sump, 300mm in diameter, and 200mm below the infiltration trench invert. The portion of stand pipe within the gravel filled sump layer shall be perforated. The flush mount well cap shall be set to base asphalt grade as per standard detail drawing CKSD 820.010 and as directed by the Contract administrator.

#### **481.03 Measurement for Payment**

Payment for this item will be for the complete installation of each observation port to finished base asphalt grade.

#### **481.04 Basis for Payment**

The price for this item shall include all labour, equipment and materials required to supply and install an observation port casing and cap at the locations specified on the contract drawings and as specified by the Contract Administrator.

## **CKSS 482 RISER PIPE OUTLET STRUCTRE**

### **REFERENCES**

OPSS 401 – Excavation, Backfilling and Compaction  
OPSS 410 – Pipe Sewer in Open Cut  
OPSS 1801 – Corrugated Steel Pipe Products  
OPSS 490 – Site Preparation

#### **482.01 Material**

##### **482.01.01 Riser Pipe**

The pipe shall be aluminized steel and shall meet CSA G401 and ASTM A929 standards. The supplied outlet structure shall include the riser pipe lid with lockable access port. The supplied outlet structure shall be approved by the Contract Administrator before installation proceeds.

##### **482.01.02 Geotextile**

Geotextile fabric shall be as per CKSS 1860.

#### **482.02 Construction**

The riser shall be placed according to the grades, profiles and alignments as indicate on the Contract Drawings. Any deviation from what is shown on the Contract Drawings must be reviewed and approved by the Contract Administrator.

A minimum of 400mm of Granular A bedding shall be provided. Bedding shall be placed in lifts not exceeding 200mm and compacted to 95% Standard Proctor Density. Backfill material shall consist of Granular B material. Backfill shall be placed in lifts not exceeding 300mm and compacted to 95% Standard Proctor Density.

#### **482.03 Measurement for Payment**

Payment shall be for each riser installed complete.

#### **482.04 Basis for Payment**

Payment for this item shall be lump sum for all labour, equipment, supply and materials required, including geotextile to complete the riser pipe installation.

## **CKSS 483 HEADWALL STRUCTURES**

### **REFERENCES**

OPSS 402 – Excavation, Backfilling and Compaction for Maintenance Holes, Catch Basins, Ditch Inlets and Valve Chambers

#### **483.01 Material**

Headwalls shall be precast concrete unless otherwise specified elsewhere in the Contract Documents.

Handrails shall be as per OPSD 980.101 or as required by the Owner and the OPSD grating noted on the drawings or elsewhere in the contract documents.

#### **483.02 Construction**

Headwalls are to be backfilled using free-draining granular material and may be designed using an active earth pressure coefficient of 0.4 and a unit weight of 21 kN/m<sup>3</sup>. Any footing shall be protected with a minimum of 1.2 m (4 ft) of earth cover or equivalent insulation to provide protection against potential frost damage.

#### **483.03 Measurement for Payment**

Measurements for installation of the structures and components will be per unit.

#### **483.04 Basis for Payment**

Payment shall be for all labour, equipment and materials including excavation, dewatering, bedding, backfill required to install headwall and railing at locations specified on the contract drawings.

Rock protection will be paid under a separate item.

# **CKSS 491**

## **PRESERVATION, PROTECTION, AND RECONSTRUCTION OF EXISTING FACILITIES**

### **REFERENCES**

OPSS 491 – Preservation, Protection, and Reconstruction of Existing Facilities  
CSA Standard Z662 – Oil and Gas Pipeline Systems; current version – Section 12 (Z662 Code)  
Guideline for Excavation in the Vicinity of Utility Lines; current version; ESA and TSSA

#### **491.01 General**

To allow Kitchener Utilities (KU) staff to respond quickly to a natural gas emergency, valves necessary for shut-off shall be accessible and quickly located.

#### **491.02 Construction**

If the valve box is exposed for construction activities in its vicinity, it shall be protected from damage during construction and be accessible at all times.

Prior to backfilling, the valve box should be inspected to ensure it is upright and free of damage and the tracer wire is secure. If the valve box requires repair, call Kitchener Utilities (Gas Emergency Number) at 519-575-4505.

Valve boxes shall be set to the finished grade and contour of the street. Valve boxes shall be protected during backfilling of the road base and during the placing or replacing of road surfaces. After paving the asphalt shall be removed, and the valve box shall be flush to grade. Valve box repairs shall be made of original manufacturer's specific box size supplied by the City of Kitchener, if required.

Sand padding is to be placed 100mm below and 200mm above the valve and is to be physically compacted. Native material to be placed in 200mm lifts and compacted by mechanical means. During compaction ensure the centre point of the valve remains vertical.

#### **491.03 Measurement for Payment**

When specified in the contract documents the payment of this item will be according to the unit of measure specified in the Schedule of Unit Prices, otherwise this work shall be considered to be included as incidental work by the Contractor required for completion of the project.

#### **491.04 Basis for Payment**

Payment at the Contract price for this work will include all equipment, materials and labour required to successfully preserve, protect, or reconstruct existing facilities.

## **CKSS 493 TEMPORARY POTABLE WATER SUPPLY SYSTEM**

### **REFERENCES**

DGSSMS

#### **493.01 General**

Temporary watermain shall be installed and commissioned prior to starting any removals.

The Contractor will be required to supply, install and maintain a temporary, potable water system and shall furnish for review and approval by Kitchener Utilities, a detailed work plan, supplemented with sketches, drawings and details as to how the system will be implemented as per the DGSSMS.

The Contractor shall visit the site prior to the tender submission to be certain of the necessary work required to complete the temporary watermain plan for fire suppression and potable water requirements.

#### **493.02 Construction**

##### **493.02.01 Source Water Connection**

The size of the backflow preventer shall be that of the largest diameter of the temporary watermain installed.

##### **493.02.02 Pipeline Installation**

Wherever the temporary watermain crosses a public sidewalk the pipe shall be buried below grade so that there is no vertical deflection along the travel path of the sidewalk. In order to maintain a clear pedestrian path the preferred location for the temporary watermain is 0.5m behind the back of the existing sidewalk where space permits.

Backfill at these locations shall be cold mix recycled asphalt compacted to 95% SPDD.

##### **493.02.03 Temporary Service Connections**

Temporary water service connections to external hose bibs are not permitted. The Contractor shall connect to the existing service connection at property line.

#### **493.03 Measurement for Payment**

Payment will be made on a pro-rated basis, 70% following supply and installation and 30% following removal of the system.

##### **493.03.01 Temporary Service Connections**

Payment for excavation of the temporary service connection at property line shall be paid for under item D.03.08.C, Hydro-vacuum excavation.

#### **493.04 Basis for Payment**

The price for this item shall include all labour, equipment, and materials (including backflow preventer), to implement and decommission the temporary watermain system, including preparation of the work plan, supply, installation, initial and ongoing bacteriological tests, and maintenance. The Contractor shall also include the cost to provide sampling of the temporary watermain. The cost for burying the temporary main at public sidewalk crossings as well as the specified backfill material shall be included in payment for this item.

The price for temporary watermain shall include the cost to connect and disconnect to properties listed in the contract documents that require an after business hour (off peak) connection to the temporary watermain system.

## **CKSS 510 REMOVAL**

### **REFERENCES**

OPSS 510 – Removal

OPSS 610 – Removal of Electrical Equipment and Materials

#### **510.01 Submission Requirements**

##### **510.01.01 Invasive Plant Species**

An invasive species removal plan shall be submitted to the Contract Administrator for review a minimum of ten (10) working days prior to excavation on site.

#### **510.02 Removal**

##### **510.02.01 Removal of Asphalt**

Unless otherwise specified in the contract documents the Contractor may remove the asphalt using methods it deems appropriate, limits of asphalt removal shall however be governed by the Construction Staging Plan and as agreed upon by the Contract Administrator.

##### **510.02.02 Removal of Asphalt, Partial Depth**

The Contractor at the direction of the Contract Administrator and as directed on the contract drawings shall cold plane the existing asphalt pavement including temporary transverse and longitudinal ramping.

Where the entire thickness of the asphalt area is removed, the Contractor shall provide and maintain a reasonable road base surface for local access of motorized vehicles and pedestrians. In addition, the unit price bid shall also include the placement of temporary ramps using existing material at all intersections, entrances, driveways and walkways within the limits of the project. If new granular material is required for temporary ramp installation, the Contractor shall be paid under the appropriate unit price bid in the Schedule of Unit Prices. Under no circumstance, shall an access or temporary ramp be removed for a significant amount of time prior to replacement of asphalt, without direction of the Contract Administrator.

The Contractor shall coordinate the cold planing of asphalt areas and subsequent replacement of the first course layer in a timely manner as not to cause a prolonged inconvenience to the public. The maximum time interval between these operations upon the completion of the asphalt removal shall not exceed a 2-day working period. Should the duration of these operations exceed this period; the Contractor shall maintain the moisture content of the road base materials as specified by the Contract Administrator by supplying and placing sufficient amounts of water and calcium chloride at their own expense.

Following the completion of the cold planning of asphalt areas, the Contractor in the presence of the Contract Administrator shall inspect all structures including sanitary and storm manholes, catchbasins, water valve chambers, water valve boxes and gas valves. All debris caused by construction must be immediately cleaned at the Contractor's expense.

##### **510.02.03 Curb and Sidewalk**

In reconstruction and/or rehabilitation projects the Contractor shall remove existing curbs or sidewalks in short sections only, as specified by the Contract Administrator. All traffic and pedestrian control procedures shall be in accordance with the latest edition of the "Occupational Health and Safety Act and

Regulations for Construction Projects" and the manual of "Uniform Traffic Control Devices, Field Edition", as issued by the Province of Ontario. In any circumstance, wherever necessary, the Contractor shall maintain and supply temporary walkways and traffic thruways using delineators, barricades, and/or caution tape as directed by the Contract Administrator.

#### **510.02.04 Unsuitable Soil Disposal**

Where and as directed by the Contract Administrator, the Contractor shall excavate unsuitable subsurface material (including trench excavation) and/or soft spots and dispose of the material off-site.

Material that is excess to the project that can be shipped to another property will be determined by the Owner's Representative through environmental and geotechnical testing. The Contractor shall excavate to the lines and grades specified in the contract and take all steps reasonable to control the flow of water for dewatering, minimize open lengths of trench, and to the extent reasonable and practicable, reuse approved native material.

#### **510.02.05 Graffiti**

The graffiti removal product selected shall be biodegradable, or else the work area shall be isolated such that none of the effluent from the removal operations enters the pond/ watercourse. The Contractor shall apply the product as per manufacturer specifications. Prior to applying the graffiti removal product, the Contractor is to clean the surface using a pressure washer. Alternatively, the Contractor may apply paint over the affected area.

#### **510.02.06 Invasive Plant Species**

The Clean Equipment Protocol for Industry shall be followed to ensure transport of invasive species through seeds/particulates on machines or equipment does not take place.

Works shall be done in accordance with all Provincial regulations, appropriate licenses and permits must be obtained prior to commencement of the works. The invasive species are to be identified, documented by a certified ecologist prior to removal works.

#### **510.02.07 Vegetation Maintenance**

The Contractor shall clear vegetation around access roads, fencing, structures, pipes using string trimmer, chainsaw, and/or hand tools. All vegetation removed shall be collected and disposed of at an approved disposal site, ensuring that none of the debris ends up in the storm water facility.

### **510.03 Salvage**

#### **510.03.01 Landscaping Features**

All material designated to be salvaged (i.e. pavers, retaining walls, etc.) shall be stored in a secure location and separated and catalogued from other like products and materials in order to maintain distinction as to its location of origin.

#### **510.03.02 Traffic / Road Signs**

The Contractor shall not remove any existing traffic or road signs. The City of Kitchener's Traffic Operations crews will remove traffic signs once the road has been closed.

## **510.04 Disposal**

### **510.04.01 Poly Vinyl Chloride Pipe**

All poly vinyl chloride (PVC) pipe removed from the trench by the Contractor shall be collected and delivered to the Owner's Operations Facility at 131 Goodrich Drive as part of The City of Kitchener's recycling program.

## **510.05 Measurement for Payment**

### **510.05.01 Removal of Asphalt**

Some driveways may have a coating of asphalt over the existing concrete and in this case, the concrete item removal will govern, i.e., one payment will be made for this removal, **not both**.

### **510.05.02 Removal of Asphalt, Partial Depth**

The price for this item shall be measure per square metre of area planed off of the existing pavement regardless of the thickness removed.

### **510.05.03 Concrete**

Measurement shall be per square metre for sidewalks, driveways and road base, per linear metre for curb and gutter, and per square metre area of the tread for steps.

### **510.05.04 Unsuitable Soil Disposal**

Payment for offsite movement of geotechnically unsuitable and designated inert soils (approved by the Owner) to another property shall be measured by the tonne using scale house tickets. If tickets cannot be provided due to the location of the disposal site the Contractor shall declare such prior to shipment of material off-site and the truck box method will be used at the time of shipment in cubic metres, as agreed upon by the Owner.

For the purposes of calculating the removal of soil by the truck box method the following values shall be used:

<u>Haulage Equipment</u>	<u>Capacity (m<sup>3</sup>)</u>
Rear Dump, Tandem Rear Axle	7.5
Rear Dump, Triaxle	11.5

For the purposes of conversion to tonnes the following conversion rates will apply for each soil type:

<u>Soil type</u>	<u>Unit Weight (kg/m<sup>3</sup>)</u>
Clay	1,900
Gravel	2,000
Sand	1,800
Silt	2,100

For soil types not listed above or for a mixture of those shown, a unit weight shall be agreed upon between the Contractor and the Owner prior to any soil excavation. If the Contractor has removed soil which does not fall under a category listed above and a unit weight has not been agreed upon between the Contractor and the Contract Administrator, a unit weight of 1,800 kg/m<sup>3</sup> shall be used.

The quantities specified for the unit prices are estimates based on the best available information. Variances of actual quantities from estimates shall not be considered as valid cause for price adjustments.

For removal of unsuitable subsurface materials measurement will be by the in-place cubic metre (m<sup>3</sup>) with no allowance for bulking and will be based on extension of the approximate average depth and approximate average square metre area of the sub-excavation based on measurements taken by the Contract Administrator's field representative at the time of work.

#### **510.05.05 Watermain and Appurtenances**

Measurement for payment for watermain and water service removal shall be per linear metre along the centre line of pipe including all inline facilities, bends, or other appurtenances, while removal of valve chambers and hydrants will be on each basis for the number of units removed under this item.

#### **510.05.06 Graffiti**

Payment shall be per square meter of surface cleaned/painted.

### **510.06 Basis for Payment**

#### **510.06.01 Asphalt**

The work of this item shall include all labour, equipment, materials and saw-cutting as required to remove asphalt pavement materials specified in the Schedule of Items and Prices, and disposal of the same off site.

#### **510.06.02 Concrete**

The work of this item shall include all labour, equipment, materials and saw-cutting as required to remove concrete road base, reinforced concrete road base, sidewalks, curb and gutter, driveways, and driveway ramps, steps and disposal of the same off site.

#### **510.06.03 Unsuitable Soil Disposal**

The work for these items shall include labour, equipment and materials required to excavate, load, transport, unload at another property, and written proof of acceptance of the material by the property owner. No additional payment shall be made for the Contractor to level, grade, or compact the material at the receiving site.

Payment of Item G.10 shall only be made for removal of soil that is unable to be compacted according to the required specifications based on in-situ testing by a Geotechnical Consultant. Where the Contractor has removed soil without the approval of the Contract Administrator no payment shall be provided to the Contractor.

If the soil to be disposed under this item exceeds MECP Table 1 Standards the appropriate premium items in unit price Schedule C shall be applied.

#### **510.06.04 Watermain and Appurtenances**

The work of this item shall include all labour, equipment and materials required to remove existing watermain pipe, valves, hydrants, watermain services and/or other appurtenances as specified in the

Schedule of Items and Prices and/or as illustrated on the Contract Drawings, all in accordance with OPSS 510, except as extended or amended herein. Payment at the Contract unit prices shall be full compensation for all specified and incidental work required to complete the items of work to the satisfaction of the Contract Administrator.

**510.06.05 Graffiti**

For the unit bid price, the Contractor shall provide all the labour, equipment and materials to remove graffiti from all structures, including headwalls, retaining walls, bridge abutments, and other locations as specified on the Contract Drawings.

**510.06.06 Invasive Plant Species**

The work for this item shall be for all labour equipment and materials required to remove and dispose of invasive plant species at locations specified on the Contract Drawings according to the Invasive Species removal plan.

**510.06.07 Vegetative Maintenance**

The work for this item shall be for all labour equipment and materials required to remove and dispose of vegetation areas at locations specified on the Contract Drawings.

## **CKSS 517**

# **DEWATERING OF PIPELINE, UTILITY, AND ASSOCIATED STRUCTURE EXCAVATION**

### **REFERENCES**

OPSS 517 – Dewatering of Pipeline, Utility, and Associated Structure Excavation  
Region of Waterloo Sewer Use By-Law 21-036

#### **517.01 General**

Surface and ground water shall only be discharged with the approval of the Owner. Water shall be tested by the Contractor (at an SCC accredited laboratory) and approved for discharge by the Owner. The Contractor shall make every effort to reduce the level of sediment in the discharge effluent.

#### **517.02 Dewatering**

The contractor shall be responsible for:

- Dewatering, depressurizing, draining, and maintaining trenches, tunnel excavations, sewer excavations, structural excavations, and foundation excavations in a stable condition;
- Protecting work against surface runoff, snow melts and rain waters;
- Providing a storage tank for temporary storage of water prior to discharge;
- Disposing of removed water as specified by OPSS 518 and CKSS 518; and
- Water control including both dewatering and depressurization of water bearing soil layers.

Dewatering includes lowering the water table and intercepting seepage which would otherwise emerge from cut slopes or bottoms of excavations, and disposing of removed water. The intent of dewatering is to increase the stability of tunnel excavations and excavated slopes; prevent dislocation of material from slopes or bottoms of excavations; reduce lateral loads on shoring; improve excavating and hauling characteristics of excavated material; prevent failure or heaving of the bottom of excavations due to hydrostatic pressure; and to provide suitable conditions for placement of foundations, backfill materials, waterproofing, drainage, and construction of structures and other installations.

Depressurization includes reduction in piezometric pressure within strata not controlled by dewatering alone, as required to prevent failure or heaving of excavation bottoms.

Excavation drainage includes keeping excavations free of surface and seepage water.

Surface drainage includes use of temporary drainage ditches and dikes and installation of temporary culverts and sump pumps with discharge lines as required to protect the work from any source of surface water.

Equipment and instrumentation for monitoring and control of the ground water control system as per conditions imposed by the MECP Permit to Take Water (PTTW), the Region of Waterloo Sewer Use By-Law 21-036 and the Compliance Agreement as contained within the Contract Documents.

The Contractor shall not discharge any water from the storage tank without the written authority of the Owner.

The Contractor shall monitor operations to verify that the dewatering system lowers ground water piezometric levels at a rate required to maintain a stable excavation, resulting in a stable subgrade for carrying out subsequent operations.

Where hydrostatic pressures in confined water bearing layers exist below excavation, depressurize those zones to eliminate risk to uplift or other instability of excavation or installed works. The piezometric elevations shall be low enough to develop a workable condition for construction operations.

The Contractor shall remove ground water control installations and remove pumping system components (such as eductors, well points, or deep wells and piping) after the permanent dewatering system is fully functional.

The Contractor shall decommission piezometers and monitoring wells in accordance with Ontario Regulation 903.

The use of submersible drainage pumps pumping at a controlled rate installed in a sump lined with 19mm clear stone acting as a filter material may be permitted with the approval of the Contract Administrator.

### **517.02.01 Performance Requirements**

Design a ground water control system to produce the following results:

- Reduce the hydrostatic pressure affecting the excavations, cut slope stability and foundation subgrades.
- Develop a stable subgrade for subsequent construction operations.
- Preclude damage to adjacent buildings, structures and utilities, and other work.
- Prevent the loss of fines, seepage, boils, quick condition, or softening of the foundation soils.
- Maintain stability of sides and bottom of excavations.

Provide drainage of seepage water and surface water, as well as water from any other source entering the excavation. Excavation drainage may include placement of drainage materials, such as crushed stone and filter fabric, together with sump pumping. Provide ditches, berms, pumps and other methods necessary to divert and drain surface water from excavation and other work areas.

Locate ground water control and drainage systems so as not to interfere with utilities, construction operations or adjacent properties.

Provide an adequate number of piezometers installed at the proper locations and depths as required to provide meaningful observations of the conditions affecting the excavations.

Protect monitoring wells installed during the site investigation.

Decommission piezometers and monitoring wells installed during site investigation as per O. Reg. 903.

### **517.02.02 Equipment and Materials**

Equipment and material selection are the prerogative of the Contractor as necessary to achieve the desired results for dewatering.

Eductors, well points, or deep wells, where used, shall be furnished, installed and operated by a Contractor licensed by the MECP as a well contractor regularly engaged in ground water control system design, installation, and operation. All equipment shall be in good repair and operating order.

Standby equipment and materials shall be kept available to ensure continuous operation, where required.

Provide thermal protection for the dewatering system against freezing temperatures where required.

### **517.02.02.01 Storage Tank for Dewatering Effluent**

The storage tank supplied by the Contractor shall include a minimum of one (1) sample port as well as a digital flow meter. The tank shall be closed from the top and shall not be open to the environment to prevent contamination of dewatering effluent.

### **517.02.03 Submittals**

Submit a Dewatering Plan for review by the Contract Administrator prior to start of any field work. The Plan shall be signed by a Professional Engineer registered in the Province of Ontario.

Submitted plan to include the following, but not limited to:

- A description of proposed groundwater control systems indicating arrangement, location, depth and capacities of system components, installation details and criteria, and operation and maintenance procedures.
- A description of proposed monitoring and control system indicating depths and locations of piezometers and monitoring wells, monitoring installation details and criteria, type of equipment and instrumentation with pertinent data and characteristics.
- Operating requirements, including piezometric control elevations for dewatering and depressurization.

Submit the following records upon completion of initial installation:

- Installation and development reports for well points, eductors, and deep wells.
- Installation reports and baseline readings for piezometers and monitoring wells.
- Initial flow rates.

Submit the following records on a weekly basis during operations:

- Records of flow rates and piezometric elevations obtained during monitoring of dewatering and depressurization.

Submit the following records at end of work:

- Decommissioning (abandonment) reports as per O. Reg. 903 for monitoring wells and piezometers installed by others during the design phase and left for Contractor's monitoring use, and those installed by the Contractor.

### **517.03 Water Control**

The control of water shall be according to OPSS 518 and CKSS 518.

### **517.04 Measurement for Payment**

#### **517.04.01 Mobilization and Demobilization**

Measurement of this item at the lump sum unit will be made regardless of the number pumps, wells etc. completed for the dewatering activity. Payment at 80% of the tendered value will be made once the dewatering system is fully operational, the remainder will be paid upon demobilization of all dewatering equipment and forces.

#### **517.04.02 Well Point Dewatering**

Measurement for this item shall be per metre of header pipe installed.

#### **517.04.03 Storage Tank for Dewatering Effluent**

Measurement for this item shall be per calendar day on-site while excavation activities are in progress.

#### **517.04.04 Monitoring Well Decommissioning**

Measurement shall be for each monitoring well (either installed as a part of the Work or installed prior to commencement of the contract) complete decommissioning, recording and delivery of recorded information to the Director of the appropriate branch of the Ministry of the Environment, Conservation and Parks.

#### **517.04.05 Lab Analysis of Water**

Measurement shall be based on each site visit conducted for the collection of water samples regardless of the number of samples collected.

### **517.05 Basis for Payment**

No extra payment for the removal of ground water from excavations will be made unless specific item(s) for well pointing systems are provided in the Schedule of Unit Prices, and any method employed by the Contractor to this end, including the use of clear-stone, shall be carried out at the Contractor's own expense. Any clear-stone used for the aforementioned purpose shall be for dewatering purposes only and shall not be accepted in lieu of specified bedding or backfill material.

#### **517.05.01 Well Point Dewatering**

The work for this item shall include all labour, materials, equipment, techniques and methods to lower, control, remove sediment and handle ground water in a manner compatible with construction methods and site conditions; monitor effectiveness of the installed system; provide for continuous system operation, including nights, weekends, and holidays; and arrange for appropriate backup when electrical power failure occurs. The Contractor shall comply with conditions in the PTTW, the Compliance Program with the Region of Waterloo for discharge to the sanitary sewer (where applicable), The Occupational Health and Safety Act, The Environmental Protection Act, regulations for Construction Projects, local by-laws and all other regulations of the Ontario Ministry of Labour and MECP Regulations for disposal of materials.

#### **517.05.02 Storage Tank for Dewatering Effluent**

The work for this item shall include all labour, equipment and materials required to supply, setup, operate, relocate and remove from the project site as required based on the Contractor's operations. There will be no direct compensation for work associated with the removal and off-site disposal of sediment from the storage tank.

If the Contractor fails to submit the flow rate data no payment will be made for this item.

### **517.05.03 Monitoring Well Decommissioning**

The work for this item shall be for all labour, equipment and materials required to decommission monitoring wells complete within the project limits.

Payment of this item will be made only after the Owner has received a copy of the well decommissioning record.

### **517.05.04 Lab Analysis of Water**

The unit price for this item shall include all costs associated with testing of water contained in the on-site temporary storage tank.

# **CKSS 518 CONTROL AND TREATMENT OF WATER FROM DEWATERING OPERATIONS**

## **REFERENCES**

OPSS 517 – Dewatering of Pipeline, Utility, and Associated Structure Excavation  
OPSS 518 – Control of Water from Dewatering Operations  
Region of Waterloo Sewer Use By-Law 21-036

### **518.01 General**

Liquids handling, liquids treatment and disposal will be the responsibility of the Contractor during all excavation and backfilling operations.

### **518.02 Construction**

#### **518.02.01 Surface Water Control**

The Contractor shall intercept surface water and divert it away from excavations through use of dikes, ditches, curb walls, pipes, sumps or other approved means. This includes temporary works required to protect adjoining properties from surface drainage caused by construction operations. Divert surface water and seepage water into sumps and pump it into designated drainage channels or storm drains. Provide settling basins as required.

#### **518.02.02 Disposal of Water**

The Contractor shall ensure that all groundwater entering excavations as well as surface water which has contacted the soils on site is collected.

##### **518.02.02.01 Direct Discharge to Sanitary Sewer**

Treatment of all dewatered liquids shall meet the Sanitary Sewer-Use By-Law 21-036 criteria and any applicable permit criteria for discharge to the sanitary sewer.

The sampling requirements for discharge to the sanitary sewer by the Regional Municipality of Waterloo (RMOW) are expected to be as follows:

- Testing a batch volume of pre-treated effluent that would be stored, tested and results forwarded to the RMOW for approval prior to discharge. The Contractor shall allow for the temporary stopping and re-starting of dewatering operations while the Region is reviewing each of the three batch data sets. After three (3) consecutive batches that successfully meet the Sanitary Sewer-Use By-Law 21-036 criteria, then discharge would occur directly to the sanitary sewer and water quality testing would occur as set out below.
- Pre-treated effluent will then be tested daily for the first week to confirm the system is functioning properly. After the first week, effluent will be tested weekly to confirm compliance with the Sanitary Sewer-Use By-Law 21-036 criteria.

The above sampling requirements will be the responsibility of the Contractor.

Provided the dewatering effluent meets the Sanitary Sewer-Use By-Law 21-036 and the sewer use agreement direct discharge to the sanitary sewer can commence following approval from the Region of

Waterloo and the Owner. Be advised that representatives from the Region of Waterloo may conduct Site inspections and sampling of treated effluent for their own independent verification that the terms of the Permit are being met. The Contractor will be in breach of the terms of this contract if it knowingly violates any condition or requirement for testing set out in the Region of Waterloo Compliance Program or described herein.

### **518.02.02.02 Water Treatment Prior to Discharge to Sanitary Sewer**

Should the dewatering effluent fail to meet the conditions of the sewer use by-law and (where applicable) the sewer use agreement, then treatment of the water may be necessary prior to discharge to the sanitary sewer.

The Contractor shall provide access to the water treatment system to the Contract Administrator and RMOW's representative for inspection and testing purposes.

The Contractor is responsible for all maintenance of the water treatment system including winterization, filter changes, and any media (e.g. granular activated carbon) changes.

From an operational view, system maintenance and filter change-out would occur on a regular basis based on routine analysis, before any level that exceeds the specified maximum permissible limit. It is the responsibility of the Contractor to assess the condition of the effluent on a regular basis and to determine when maintenance is required and to ensure that effluent discharged to the sanitary sewer does not exceed the permissible limit.

A flow meter will be installed to record the actual volume of discharged water. Test ports before and after the treatment filters will allow for sampling collection for laboratory analysis of target compounds before treated groundwater is discharged to the sewer. The proposed effluent quality will not result in an odour concern within the sewer.

To confirm that the Contractor's mobile water treatment unit is functioning satisfactorily the Contractor shall proceed as follows:

- A batch volume of treated effluent would be stored and tested to confirm compliance with O.Reg. 511/09 (as amended) Table 2 Standards, the Region of Waterloo Sewer Use By-Law 21-036, and any other applicable limits as set out in the Compliance Program with the Region of Waterloo. If contaminants are detected above the respective limits in the effluent, the batch volume of water shall be retreated at the Contractor's expense. The retreated batch(s) of effluent will be retested at the Contractor's expense until compliance is confirmed.
- The Contract Administrator upon receipt of satisfactory laboratory analysis that confirms that the treated effluent does not exceed the respective limits will authorize the Contractor to discharge the treated effluent to the sanitary sewer with any and all conditions set out in the valid and proper Environmental Compliance Approval(s) (ECA), and/or Region of Waterloo Compliance Program.
- All subsequent operation and conformance to the ECA for discharge to the sanitary sewer shall be the responsibility of the Contractor. This shall include testing, reporting, monitoring requirements.

Operation of the treatment facility and discharge to the sanitary sewer shall not be permitted without written authorization from the Owner.

### **518.02.02.03 Water Treatment Prior to Discharge to Storm Sewer**

When the Contract Documents call for discharge to the storm sewer the Contractor shall treat the dewatering effluent to Provincial Water Quality Objectives (PWQO) concentration levels.

From an operational view, system maintenance and filter change-out would occur on a regular basis based on routine analysis, before any level that exceeds the specified maximum permissible limit. It is the responsibility of the Contractor to assess the condition of the effluent on a regular basis and to determine when maintenance is required and to ensure that effluent discharged to the storm sewer does not exceed the permissible limit.

A flow meter will be installed to record the actual volume of discharged water. Test ports before and after the treatment filters will allow for sampling collection for laboratory analysis of target compounds before treated groundwater is discharged to the sewer. The proposed effluent quality will not result in an odour concern within the sewer.

To confirm that the Contractor's mobile water treatment unit is functioning satisfactorily the Contractor shall proceed as follows:

- A batch volume of treated effluent would be stored and tested to confirm compliance with O.Reg. 511/09 (as amended) Table 2 Standards, the Region of Waterloo Sewer Use By-Law 21-036 and Provincial Water Quality Objectives (PWQO). If contaminants are detected above the respective limits in the effluent, the batch volume of water shall be retreated at the Contractor's expense. The retreated batch(s) of effluent will be retested at the Contractor's expense until compliance is confirmed.
- The Contract Administrator upon receipt of satisfactory laboratory analysis that confirms that the treated effluent does not exceed the respective limits will authorize the Contractor to discharge the treated effluent to the storm sewer with any and all conditions set out in the valid and proper Environmental Compliance Approval(s) (ECA).
- All subsequent operation and conformance to the ECA for discharge to the storm sewer shall be the responsibility of the Contractor. This shall include testing, reporting, monitoring requirements.

Operation of the treatment facility and discharge to the storm sewer shall not be permitted without written authorization from the Owner.

### **518.02.02.04 Water Treatment Prior to Discharge to Grade**

When the Contract Documents call for discharge to grade the Contractor shall treat the dewatering effluent to PWQO concentration levels. The Contractor shall dispose of the dewatering effluent in accordance with the sediment and erosion control plan.

A flow meter will be installed to record the actual volume of discharged water. Test ports before and after the treatment filters will allow for sampling collection for laboratory analysis of target compounds before treated groundwater is discharged to the sewer. The proposed effluent quality will not result in an odour concern within the sewer.

To confirm that the Contractor's mobile water treatment unit is functioning satisfactorily the Contractor shall proceed as follows:

- A batch volume of treated effluent would be stored and tested to confirm compliance with Provincial Water Quality Objectives (PWQO). If contaminants are detected above the respective limits in the effluent, the batch volume of water shall be retreated at the Contractor's expense.

The retreated batch(s) of effluent will be retested at the Contractor's expense until compliance is confirmed.

- The Contract Administrator upon receipt of satisfactory laboratory analysis that confirms that the treated effluent does not exceed the respective limits will authorize the Contractor to discharge the treated effluent to grade with any and all conditions set out in the valid and proper Environmental Compliance Approval(s) (ECA).
- All subsequent operation and conformance to the ECA for discharge to grade shall be the responsibility of the Contractor. This shall include testing, reporting, monitoring requirements.

Operation of the treatment facility and discharge to grade shall not be permitted without written authorization from the Owner.

### **518.03 Off-Site Water Disposal**

If instructed by the Contract Administrator to dispose of groundwater to an MECP approved disposal facility, the Contractor is solely responsible for arranging a disposal facility including manifesting and providing any analytical data that the disposal facility requires. The Owner shall provide the Hazardous Waste Information Network (HWIN) number to the Contractor.

### **518.04 Measurement for Payment**

Payment for groundwater treatment items will only be made if the dewatering effluent does not meet regulated concentrations as set out in applicable legislations, by-laws or agreements.

Measurement for this item shall be per calendar day on-site while excavation activities are in progress.

### **518.05 Basis for Payment**

#### **518.05.01 Discharge**

There will be no direct compensation for the labour, equipment and materials required to discharge dewatering effluent when no water treatment has been applied.

#### **518.05.02 On-Site Water Treatment**

Payment for mobilization and demobilization shall only be paid upon written authorization from the Contract Administrator permitting the Contractor to setup the mobile treatment facility on-site.

The Contractor is responsible for all maintenance of the water treatment system including winterization, filter changes, and any media (e.g. granular activated carbon) changes. The Contractor is also responsible for any costs incurred for the changing and disposal of any spent carbon or other media from the water treatment plant. Water quality may be variable indicating that concentrations of detected compounds may fluctuate. No additional payment or claim will be considered for any costs incurred such as changing of carbon units, filters.

Costs are to include all labour, equipment and supplies for cleaning, start-up, continuous operation and maintenance of the system and components for the duration of dewatering activities, including all mandatory reporting requirements. Costs also include all labour, equipment and supplies related to changes of filters and filter media.

No additional payment will be made for power supply and use, winterization, movement of the system and associated equipment within the limits of the project site, re-processing of treated water, site security,

malfunction of equipment, addition/removal of treatment components, standby time, system modification due to improper operation, maintenance, testing, or sampling pursuant to the ECA, Region of Waterloo Compliance Program and/or Provincial Water Quality Objectives are to be made by the Contractor.

No payment will be made for discharge of treated groundwater to the sewer without written approval from the Owner.

### **518.05.03 Off-Site Water Disposal**

Payment for the handling and offsite disposal of wastewater to a licensed wastewater treatment facility to include all load manifests, testing fees by the receiver, reporting requirements, vacuum truck equipment, and miscellaneous pumps and hoses. No additional payment will be made for truck standby time during loading and unloading, loads rejected by the receiver, load restriction or surcharges.

## **CKSS 560**

### **PRECONDITION SURVEY OF STRUCTURES**

#### **560.01 General**

The Contractor will retain a specialist firm to conduct pre-condition inspections of structures in proximity to this project, record the condition of such structures, make arrangements for a program of vibration monitoring during the construction (as may be necessary), and conduct follow-up inspections and investigations (as maybe necessary).

The completion and verification, in writing to the Owner, that all pre-condition inspections of all structures shall be done before the scheduled start of construction. Failure to satisfy this condition may be treated, at the Owner's discretion and without claim of waiver, as a material breach of the contract.

#### **560.02 Work**

The general requirements for these surveys will include a video and photographic record, a fully documented (hardcopy and digital PDF) inventory and bound report(s) with photographic examples. The report shall include a reference map showing buildings surveyed by location and a summary of significant and/or notable deficiencies or matters of concern to the proposed project. The inspection and survey report shall document the following minimum information:

##### **Conditions of:**

Building Exterior - all exposed walls, doors, windows, roof if possible and any other permanent or fixed structures, including, retaining walls, garage(s), carport(s), landings, porches, etc.

Building Interior - all rooms, exposed walls, floor and ceiling, doors, windows, stairs and landings as well as any other pertinent fixtures.

Landscaping Features - such as fountains, garden walls, driveways and hard surfaced walkways (concrete, impressed concrete, etc.)

Before the pre-condition surveys are carried out, the Contract Administrator will provide an introductory letter explaining the purpose and procedure of the survey. The letter shall be delivered by the Contractor to each property owner prior to the survey being undertaken.

#### **560.03 Measurement for Payment**

Measurement for payment will be lump sum with 50% paid upon project startup and the remainder being paid in full once the final reports have been provided to the Owner.

#### **560.04 Basis for Payment**

This Item shall include all labour, equipment and materials required to provide a complete pre-condition survey of structures as required by the scope of the work, including the submission of the detailed survey results to the Owner prior to the scheduled start of construction, and follow up inspections as required.

## **CKSS 561**

### **TEST PITS FOR SOIL CHARACTERIZATION**

#### **561.01 Construction**

##### **561.01.01 Test Pits During Construction**

The Contractor shall excavate at locations agreed upon with the Contract Administrator test pits to a minimum of 1.2m below ground surface (b.g.s.) for the purposes of obtaining soil samples for characterization of contaminants.

The Contractor shall upon completion of the test pit backfill with the excavated material. For projects where this work forms the part of a larger contract, granular A shall be used for restoration to existing grade above the backfilled material, all granular material to be compacted to 100% SPDD.

##### **561.01.02 Exploratory Test Pits**

The Contractor shall upon completion of the test pit backfill with the excavated material and compacted to 95% SPDD. Asphalt edges shall be saw-cut in a diamond pattern in the direction of the flow of traffic. A minimum of 90 mm of HL4 (two lifts of 45mm) asphalt (compacted to 98% SPDD) placed to finished grade.

#### **561.02 Basis for Payment**

The work of this item shall include all labour, equipment, materials and sawcutting as required to excavate, stockpile, and backfill test pits for soil characterization to the depth specified in the Contract Documents and locations as directed by the Contract Administrator.

Payment for restoration items such as asphalt shall be paid for under their respective items in the Schedule of Unit Prices.

## **CKSS 562 PROVIDE GARBAGE, RECYCLE, GREEN BIN AND YARD WASTE PICK UP AND TRANSPORTATION**

### **562.01      General**

The Contractor will be required to pick up, transport, and return (in the case of bins) garbage, recycle, green bin and yard waste materials when access to these areas are denied because of the Contractor's activities or deemed unacceptable by the Region of Waterloo's Waste Management Division.

### **562.02      Measurement for Payment**

Payment for this item will be pro-rated to match the percentage of the work completed at the time of each progress payment certificate.

### **562.03      Basis for Payment**

The work of this item shall include all costs associated with the pickup and transportation of garbage, recycle, green bin and yard waste items, as required by the Regional Municipality of Waterloo, Waste Management Division as well as other waste collection firms.

## **CKSS 563**

### **RAILWAY FLAGMAN AND INSPECTION**

#### **563.01      General**

The Contractor shall be responsible for coordinating with the Railway Authority to arrange for their on-site inspector(s) to be present for the duration of any work within or adjacent to the Railway Right-of-way as required by the Railway Authority.

#### **563.02      Basis for Payment**

The Contractor shall be responsible for all Railway inspection costs, including all incidental items as provided in the Schedule of Unit Prices. Any inspection costs over and above the amount listed in the Schedule of Unit Prices shall be at the Contractor's expense and shall be considered a full part of the work.

## **CKSS 564 UNSHRINKABLE BACKFILL**

### **REFERENCES**

OPSS 1359 – Material Specification for Unshrinkable Backfill

#### **564.01 Material**

The controlled density fill material used shall be a ready mixed flowable fill as manufactured by ready mixed concrete producers. The controlled density fill shall consist of and meet the following requirements:

Cement

- Type 10 Portland Cement
- 25 kg/m<sup>3</sup>

Aggregates

- In accordance with CSA (CAN3-A23.1)

Slump

- 160mm to 200mm for trench backfill, or as per pumping specifications

Strength

- maximum 0.7MPa at 28 days

Air Entrainment

- In accordance with CSA (CAN3-A23.1)

#### **564.02 Construction**

The Contractor is to ensure the method and equipment being used will not damage the abandoned pipe.

#### **564.03 Measurement for Payment**

Payment shall be at the Contract unit price per cubic metre for filling abandoned pipe or for use as trench backfill, and shall be full compensation for all specified and incidental work, to the satisfaction of the Contract Administrator.

#### **564.04 Basis for Payment**

The work of this item shall include all labour, material and equipment required to supply and place controlled density fill, to fill in-situ voids and abandoned pipes inaccessible to mechanical compaction equipment, in order to provide protection and structural support to utilities and other plant as requested by the Contract Administrator.

## **CKSS 565 SITE OFFICE**

### **565.01 General**

The Contractor shall provide for the duration of the Contract, for the sole use of the Contract Administrator and its representatives, a field office in good, clean condition (mold free, dirt/dust free, secure from vermin and other pests) having a minimum floor area of 12.0m<sup>2</sup>, a plan bench 1.0m wide x 2.4m long including a drafting stool, adequate windows, a telephone and an electrical service hookup (which shall be maintained by the Contractor at the Contractor's expense), a lockable door, a desk with drawers and four chairs. The office shall be heated and/or cooled (at the Contractor's expense), to maintain a temperature level between 20 degrees C and 24 degrees C. The office shall be erected and moved as, where and when the Contract Administrator directs. The office shall be maintained in a clean condition by the Contractor. On completion of the contract work, or as otherwise directed by the Contract Administrator, the field office shall be removed from the site by the Contractor. The site office shall remain the property of the Contractor.

The Contractor shall provide and setup a Wi-Fi internet connection in the site office. The cost for an Internet Service Provider shall be included in the unit price.

The Contractor shall also provide an air-conditioning window unit, fire extinguisher, magnetic bulletin board (minimum size 24 inches x36 inches) complete with magnets up request, and first aid kit for the site office.

### **565.02 Basis for Payment**

Payment for this item will be pro-rated to match the percentage of the work completed at the time of each progress payment certificate and shall be for the supply, operation, maintenance, and removal of the site office as described herein.

Site offices delivered to the site in an unacceptable condition that does not meet the general requirements set out in CKSS 565.01 as determined by the Contract Administrator shall be refused and replaced at no additional cost to the Owner.

## **CKSS 603 INSTALLATION OF DUCTS**

### **REFERENCES**

OPSS 603 – Installation of Ducts  
OPSD 2101.01 – Duct Installation in Trenches

#### **603.01 Material**

Unless otherwise noted on the Contract Drawings or in the Schedule of Unit Prices the following approved materials should be used according to their corresponding installation method:

- Rigid PVC Type 2 (open cut installation)
- HDPE DR13.5 (trenchless installation)

#### **603.02 Construction**

Duct shall be complete with solvent welded joints for PVC, and butt fused for HDPE, caps on all open ends and a fish line as per OPSD 603 for cable pulling through the duct. A minimum of three (3) metres of fish line shall be rolled up at each end of the duct outside of the cap to provide sufficient working material for pulling.

A minimum of 100mm of sand compacted to 100% SPDD shall be used for bedding material, with a minimum cover above the largest duct obvert (in the duct bank) of 300mm of sand compacted to 98% SPDD.

#### **603.03 Measurement for Payment**

Payment will be made per linear metre of duct installed regardless of the method of installation unless otherwise indicated in the Schedule of Unit Prices.

#### **603.04 Basis for Payment**

The work of this item shall include all labour, materials, equipment required to install duct at locations specified on the contract drawings. The price for this item shall also include the installation of electronic ball markers as provided by the Telecommunications Company and coordination with the respective stakeholder.

## **CKSS 609 GROUNDING**

### **REFERENCES**

OPSS 609 – Grounding

#### **609.01 Construction**

Where the remaining length of water service from a building face to the curb stop will be less than three (3) metres the Contractor shall ensure grounding for the building is being provided. The method of grounding shall be compliant with ESA regulations at the discretion of the Contractor.

#### **609.02 Quality Control**

The City will require an ESA certificate to ensure proper installation practices have been followed.

#### **609.03 Measurement for Payment**

Measurement for this item will be for grounding of each building.

#### **609.04 Basis for Payment**

The work for this item shall include all labour, equipment, materials, permits and inspections necessary to provide grounding to buildings. Payment in the full amount shall be made upon the Contract Administrator receiving the Certificate of Conformance from the Contractor.

## **CKSS 706**

# **TRAFFIC CONTROL, VEHICULAR AND PEDESTRIAN SIGNAGE**

### **REFERENCES**

OTM Book 7  
OPSS 706 – Traffic Control Signing

#### **706.01 General**

All traffic control devices shall be clearly marked with the contractor's name, shown on the non-retroreflective surface. The marking shall be a non-retroreflective colour.

#### **706.02 Measurement for Payment**

The work of this item shall include all labour, equipment and materials required to provide traffic control measures and installation/removal of signage in accordance with the Occupational Health and Safety Act for Construction Projects and as outlined in the Contract documents. The work shall also include all coordination efforts required by the Contractor to deal with traffic operations in conjunction with the City of Kitchener, the Regional Municipality of Waterloo, emergency services, Grand River Transit, School Board transit and other needs of the community.

#### **706.03 Basis for Payment**

Payment on a percentage of completion basis shall be considered compensation in full for all specified and incidental work required by the Contractor to coordinate traffic control and operations on this Contract. Payment will be made on a pro-rated basis determined on each payment certificate based on the percentage of project completed.

# **CKSS 710 PAVEMENT MARKINGS**

## **REFERENCES**

OTM Book 11  
OTM Book 18  
OPSS 710 – Construction Specification for Pavement Marking

### **710.01 General**

Where the work is staged the Contractor shall install temporary pavement markings to delineate the centre line of the road, multiple vehicular lanes (as applicable) and stop bars.

The Contractor shall commence the installation of the permanent pavement markings following City (and Regional where applicable) staffs approval of pre-marking layout and within 48 hours of completing asphalt paving.

If the Contractor completes the permanent pavement marking application incorrectly without having gained approval from the Owner of the pre-marking layout prior to commencement of the permanent pavement marking, the Contractor will be required to remove the incorrect markings and reinstall them correctly at the cost of the Contractor.

### **710.02 Material**

Material type shall be as specified on the pavement marking plan or as directed by the Contract Administrator.

Durable pavement markings are to be thermoplastic or cold plastic.

#### **710.02.01. Temporary Pavement Markings**

OPS 532.07.08 is amended by the deletion of the 4th paragraph and the following added:

Where the Contractor must apply Pavement Marking, Temporary Removable, the Contractor shall use 3M Stamark Wet Reflective Removable Tape (A780WR white or A781WR yellow) or approved equivalent wet reflective removable tape.

Temporary 3M Stamark Wet Reflective Removable Tape to be supplied by the Contractor.

### **710.03 Construction**

Pavement marking configuration shall be applied in accordance with the pavement marking drawings, OTM Book 11, OTM Book 18, and as directed by the Contract Administrator. The City (and Region where applicable) shall approve the Contractor layout of pavement markings prior to commencing any installations.

#### **710.03.01 Application**

Stop bars shall be 60cm wide; crossing ahead markings shall be 30cm wide.

### **710.03.01.01 Thermoplastic Pavement Marking Material**

Delete the first paragraph of OPSS 710.07.09.04 and replace with the following:

The minimum surface temperature for application shall be 10 degrees Celsius and a maximum surface temperature shall be 35 degrees Celsius. Maximum relative humidity shall not exceed 70%.

### **710.03.01.02 Water-Borne Traffic Paint**

Two coats of water-borne paint shall be applied immediately regardless of atmospheric temperature.

## **710.04 Measurement for Payment**

### **710.04.01 Water-Borne Traffic Paint**

Payment will be made as per the unit of measure in the tender item. Measurement shall be continuous for each coat of paint applied.

### **710.05 Basis for Payment**

The work of this item shall include all labour, material and equipment necessary to provide pavement markings, including temporary marking (as necessary where multiple stages exist) as shown on the Contract Drawings and as directed by the Contract Administrator.

## **CKSS 760 TRAFFIC SIGN INSTALLATION**

### **REFERENCES**

OTM Book 5  
OTM Book 6  
OTM Book 8

#### **760.01 Material**

All sign sleeve inserts, posts, and brackets for installation of signs are to be supplied by the Owner given 10 working days' notice.

All traffic signs to be installed will be supplied by the Owner.

#### **760.02 Construction**

Install sign sleeve inserts as indicated on the contract drawings or as directed by the Contract Administrator in accordance with RMW Standard Drawing 508. Sign sleeves to be PVC Conduit Sleeves set plumb and capped with duct tape.

A sign inventory will be supplied to the Contractor by the Owner for locations of traffic signs. The Traffic Project Coordinator will meet with the Contractor to review and pre-mark installation locations. Upon completion of installation the Contractor will notify the Owner for inspection purposes.

#### **760.03 Measurement for Payment**

Payment for the installation of traffic signs shall be per each location and not per traffic sign installed. Where a sleeve and post are installed in the same location they shall be measured as one (1) combined installation.

#### **760.04 Basis for Payment**

The Contractor shall be responsible for any relocation costs associated where the initial sign placement by the Contractor was incorrect.

The Contractor shall be responsible for any costs associated for replacement of signs due to damage or theft as a result of improper storage.

## **CKSS 801 TREE PROTECTION**

### **REFERENCES**

OPSS 801 – The Protection of Trees

#### **801.01 Construction**

The work of this item shall include all labour, equipment and materials required to supply, erect, and maintain temporary fencing (orange, plastic fence, 1.2 metre high with metal “T” bar supports at maximum 6 metre spacing) complete with a 10mm nylon top rope (woven through the top of the fencing). Fencing to be located around existing trees (as specified on the Tree Management Plan) and/or along both sides of the roadway (at the curb line or sidewalk area), to protect the trees and pedestrians from the Contractor’s activities. Fencing may also be located to delineate other construction activities as noted elsewhere in the Special Provisions.

#### **801.02 Measurement for Payment**

##### **801.02.01 Tree Protection Fencing**

Measurement for this item will be on a linear metre basis for all new temporary fencing installed on the project irrespective of the number of occasions the temporary fence may be relocated for construction purposes.

#### **801.03 Basis for Payment**

##### **801.03.01 Tree Protection Fencing**

The work for this item shall include all labour, equipment and materials necessary to setup, maintain and remove tree protection fencing as directed by the Contract Administrator.

The Contractor shall include in the pricing of this item, any and all costs required to remove and reinstate sections of the protective fencing as may be required for the removal and replacement of lateral services, utilities, and related work.

Payment shall be 70% of the unit price upon initial installation and the 30% balance upon removal.

## CKSS 802 TOPSOIL

### REFERENCES

OPSS 802 – Topsoil

#### 802.01 Material

##### 802.01.01 Topsoil

Topsoil shall be screened, friable, neither heavy clay nor of very light sandy nature; containing 2% organic material for sandy loams to a maximum of 20% by volume. Topsoil shall meet the classification of Sandy Loam or Loam as described in the Soil Texture Classes Triangle from Government of Canada Agriculture and Agri-Food Canada guidelines (see below). Imported topsoil shall be free from subsoil, roots, grass weeds, toxic materials, stones, foreign objects and with an acidity range (pH) of 6.5 to 7.5. Topsoil containing crabgrass, couchgrass or noxious weeds will not be accepted.

The Contractor shall provide certification of testing and compliance of all imported topsoil material prior to the material arriving on site. The contractor shall inform the Contract Administrator of any change in supplier or location of stockpile and an updated certification of testing and compliance shall be provided.

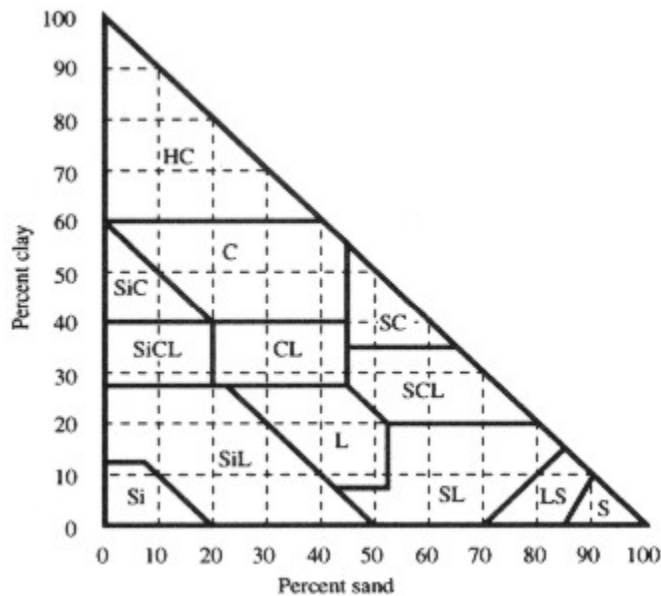

Digital web image, Government of Canada Agriculture and Agri-Food Canada, <http://sis.agr.gc.ca/cansis/ta/cssc3/chpt17.html>

Soil Texture Classes Triangle. Percentage of clay and sand in the main textural classes of soil; the remainder of each class is silt. Abbreviations for the texture classes are: HC, heavy clay; C, clay; SiC, silty clay; SiCL, silty clay loam; CL, clay loam; SC, sandy clay; SiL, silt loam; SCL, sandy clay loam; SL, sandy loam; Si, silt; LS, loamy sand; S, sand, L, Loam.

### **802.01.02 Fertilizer**

Fertilizer shall comply with the provisions of the Canada Fertilizers Act and Fertilizer Regulations. Fertilizer shall be granulated 8-32-16 ration, complete synthetic slow-release with maximum 35% water soluble nitrogen.

### **802.02 Construction**

The placement of topsoil shall not commence until the Contract Administrator has approved the subgrade surface preparation. A minimum of one (1) full working days' notice is required for inspection prior to placement of topsoil.

#### **Amendment to OPSS 802.07.03 – Placement of Topsoil**

Replace subsection 802.07.03 in its entirety with the following:

Screened topsoil shall be spread to a minimum compacted depth of 150mm. The Contractor shall fine grade, to a uniform surface, the areas or locations to be dressed with topsoil. In order to ensure proper integration of the topsoil with existing surface, the latter shall be free of all vegetation and other debris and free of stones, and shall be loose to a depth of 25mm at the time of placing topsoil. The Contractor shall perform such mowing, raking and picking up of debris, and such discing, harrowing or other means of scarification as may be necessary to comply with this requirement, and shall dispose of all debris at the Contractor's expense. All clods or lumps shall be pulverized and any roots or foreign matter shall be raked up and removed by the Contractor. Surface shall then be rolled in two directions and all depressions filled and smoothed. Topsoil shall be level with the sidewalk and curb. All surfaces on which sod is placed shall be loose, at the time of placing the sod. The 150mm soil profile shall not exceed 200 psi of soil compaction within the warranty period as taken from the Dickie-John Soil compaction Tester (penetrometer) or similar testing equipment.

Fertilizer shall be applied at the rate recommended by the manufacturer specifications.

When topsoil is placed and results in competitive growth due to the General Contractor's or Sub-Contractor's schedule, the Contractor is responsible for de-weeding at their own cost, unless otherwise directed by the Contract Administrator.

### **802.03 Measurement for Payment**

Measurement for payment will be on a cubic metre basis, as per quantities placed; complete with submission of printed truck weigh tickets supplied upon delivery to site.

### **802.04 Basis for Payment**

The work of this item shall include all labour, equipment and material required to import place, grade and fertilize screened topsoil.

## **CKSS 803 SODDING**

### **REFERENCES**

OPSS 803 – Sodding

#### **803.01 Material**

##### **803.01.01 Sod**

Sod shall be No. 1 grade nursery grown sod to specifications published by the Canadian Nursery Trades Association. The sod shall be in vigorous growing condition, free from weeds and crabgrass, cut from well-established turf, permeated with roots and contains sufficient moisture to maintain its vitality during transportation and placing.

No. 1 Kentucky Bluegrass sod shall be grown from minimum 100% Kentucky Bluegrass in accordance with the Classifications of the Nursery Sod Growers Association of Ontario. Sod shall contain no more than 2% of other strains or species of grasses or clover of which twitch grass shall not constitute more than 0.5%. Sod shall be two years old from the time of original seeding be well rooted, free from stones, grubs and burned or bare spots, and shall be fresh at the time of lying.

##### **803.01.02 Fertilizer**

Fertilizer shall comply with the provisions of the Canada Fertilizers Act and Fertilizer Regulations. Fertilizer shall be granulated complete synthetic slow release with maximum 35% water soluble nitrogen.

#### **803.02 Construction**

The placement of sod shall not commence until the Contract Administrator has approved the surface preparation of topsoil. A minimum of one (1) full working days' notice is required for inspection prior to placement of sod.

All sod shall be cut by able methods by machines designed for that purpose, to the supplier's length and width, plus or minus 12 mm in width and plus or minus five percent (5%) in length. Broken pieces and torn or uneven ends are not acceptable. Sod shall be cut at a uniform soil thickness (excluding top growth and thatch) of 15 mm plus or minus 5 mm.

All sod shall be placed the day it is cut. The Contractor shall provide tickets from the sod supplier to the Contractor Administrator prior to placing the sod on-site.

The Contractor shall review the bare topsoil areas to be sodded after watering and shall repair any rutting or troughs caused by erosion as a result of watering topsoil.

All watering to abide by Table 1 - Sod Watering Table refer to section 803.02.01 Maintenance of Completed Sodding.

Fertilizer shall be delivered to the site in standard containers, labeled to indicate its weight, analysis and manufacturer. Fertilizer shall be stored in such a manner that it is kept dry, and its effectiveness is not impaired.

All new sod shall have tight seams, proper grading and placement at edges, and rolled using a turf roller immediately to ensure good contact between the turf roots and the soil. The turf roller weight shall be empty 530 lbs. (240 kg) and full 1010 lbs. (457 kg).

### 803.02.01 Maintenance of Completed Sodding

OPSS 803.07.05 (Maintenance of Completed Sodding) is amended in that all references to a “30 day maintenance period” are replaced with a “60 day maintenance period”.

Add the following to OPSS 803.07.05 - Maintenance of Completed Sodding

#### 803.02.01.01 Watering

Water shall not have contaminants or impurities that would adversely affect the germination and growth of vegetation. Water shall be applied to new sod immediately (within 1 hour) after placement and is to be watered a minimum frequency as per the chart below. The Contractor shall verify complete soak through of the sod upon completion of watering.

**Table 1 - Sod Watering (Unless otherwise provided included in Sod Unit Pricing)**

*Note: all weeks are based on 7-day growing week after the date of placement.*

Timeframe	Frequency of Watering
Prior to sod placement (on the same day of sod placement)	Water shall be applied to the topsoil no more than 4 hours before the placement of sod, penetrating to a depth of 25mm.
At time of sod placement	Water shall be applied to new sod immediately (within 1 hour after placement to saturate the entire area, with 25mm to 50mm of water applied per 1m <sup>2</sup> ).
1 <sup>st</sup> week following sod placement	Every day of the first week (7 daily waterings minimum with 25mm of water applied each time per 1m <sup>2</sup> )
2 <sup>nd</sup> week following sod placement	Every other day of the second week (4 waters per week minimum with 25mm of water applied each time per 1m <sup>2</sup> )
3 <sup>rd</sup> week following sod placement	3 times in the third week minimum (3 waters per week minimum with 25mm of water applied each time per 1m <sup>2</sup> )
4 <sup>th</sup> week following sod placement and until the expiry of the 60-day maintenance period	Weekly watering to provide a minimum of 50mm per 1m <sup>2</sup> of water on new sod per week, until the end of 60-day sod maintenance period and sod acceptance by Contract Administrator.

The Contractor shall fully soak the topsoil prior to placement of sod. Water shall be applied as shown in Table 1 above. Water shall be applied in such a way that runoff of water and sediment is prevented.

Additional watering could be required based on the time of the year and/or heat stress pressures.

The Owner prohibits direct water taking from the hydrants. Purchase of water at the Bulk Water Filling Station can be made available to Contractors by contacting the City by calling 519-741-2600 extension 4094.

#### 803.02.01.02 First Cut

The Contractor shall be responsible to perform the first cut on all new sod, using sharpened mower blades and must bag and remove all mower clippings off of hard surfaces (sidewalk and driveway). The first cut shall occur no later than 2 weeks (14 days) after install to allow for establishment / rooting to occur, cutting to a height of 75mm or 1/3 of height of plant.

**Contractor notification for First Cut:** The Contractor shall notify, in writing, each property and the Contract Administrator on the date the first cut takes place. The same notice shall be supplied to the Contract Administrator in advance for review a minimum of five (5) working days.

As a minimum, the Contractor notice letter for First Cut letter shall include:

- i. Contract name and number.
- ii. Work location and limits
- iii. Contractor contact name and number.
- iv. Nature of work
- v. Anticipated start date and duration.

**City notification to Residents:** The City will inform residents that they are not to mow the sod until after the first cut has been completed by the Contractor.

### **803.02.01.03 Aeration, Fertilization, and Overseeding**

The Contractor shall be responsible to perform aeration, fertilization and overseeding mix of the new sod the following calendar year, as soon as possible in early spring at a rate of 36 cores/sq.ft or 7% of the overall area by core aeration.

The Contractor shall complete aeration, fertilization and overseeding a second time in the spring season in year two (2) of the maintenance period.

Fertilizer shall be applied the same day the sod is aerated and again when overseeding the following calendar year, as soon as possible in the early spring. Fertilizer shall be applied at the rate recommended by the manufacturer specifications.

Overseeding shall be applied at the same time as aeration and fertilizer. Overseeding mix shall be as per CKSS 804.01.02. Overseeding shall be applied at the rate recommended by the manufacturer specifications.

**Contractor notification for Aeration, Fertilization and Overseeding:** The Contractor shall notify in writing each property and the Contract Administrator on the date the aeration and fertilizer takes place. The same notice shall be supplied to the Contract Administrator in advance for review a minimum of five (5) working days.

As a minimum, the Contractor notice letter for Aeration and Fertilizer letter shall include:

- i. Contract name and number.
- ii. Work location and limits
- iii. Contractor contact name and number.
- iv. Nature of work
- v. Anticipated start date and duration.

### **803.03 Quality Assurance**

OPSS 803.08.01 (Performance Measure) and 803.08.02 (Acceptance) is amended in that all references to a "30 day maintenance period" are replaced with a "60 day maintenance period".

The Contract Administrator will inspect the sod at time of placement and will notify the Contractor of any deficiencies. The City will provide residents with an installation sod placement notice informing them of the 60-day maintenance period and Contractor responsibilities as it relates to new sod. The Contract Administrator will inspect the sod again at the end of the 60-day sod maintenance period and will notify the Contractor of any sod deficiencies that have not been accepted. The Contract Administrator will provide a notice to residents at the end of sod maintenance period, to the sodded properties that have

been accepted. The Owner may perform additional inspections based on resident comments and feedback during the sod maintenance period.

All new sod areas shall be healthy, actively growing, and green in leaf colour with full root establishment. All sod shall be in the same location as originally placed and shall not have moved, eroded, slipped, or sloughed. Sod shall show evidence of rooting in the underlying soil. The sod shall be of sufficient density that no surface soil is visible. There shall be no competitive growth emerging from the sod or from between the sod joints. The Contractor shall replace (at no additional cost to the Owner) any sod areas, which in the sole opinion of the Owner does not meet these quality control criteria.

Any settlements in sodded areas arising from excavation work as part of this project will be the responsibility of the Contractor for the full duration of the warranty period as defined in SGC 1. All replacement sod will be subject to the same placement, care and warranty requirements outlined within this specification. The Certificate of Final Acceptance for this project will be withheld until all sod in the above-mentioned rectification areas has met the time requirements described herein.

## **803.04 Measurement for Payment**

### **803.04.01 Sod**

Payment shall be on a square metre basis of sod laid. Payment shall be pro-rated based at 70% once the sod is laid and rolled using a turf roller. The remaining 30% shall be paid once all of the sod is accepted at the end of the 60-day maintenance period.

### **803.04.02 First Cut**

Payment shall be per cut and notification completed for each stage of the project.

### **803.04.03 Aeration, Fertilizer, Overseeding and Notification**

Payment shall be for aeration, fertilization, overseeding and notification complete for each stage of the project. Payment of this item shall not be counted if any one (1) of these components is not completed as part of the work.

### **803.04.04 Watering**

Payment shall be per watering of sod complete.

## **803.05 Basis for Payment**

The work of this item shall include all labour, equipment, material to place sod, water, turf roll, first cut, aerate (twice), fertilize, overseed and provide notifications required to do the work.

### **803.05.01 Sod**

The work of this item shall include all labour, equipment, material to place sod, watering of topsoil, turf roll, first cut, and provide notifications required to do the work.

### **803.05.02 First Cut**

The work of this item shall include all labour, equipment, material to complete the first cut of sod, and provide notifications to residents.

### **803.05.03 Aeration, Fertilizer, Overseeding and Notification**

The work of this item shall include all labour, equipment, and material to aerate, fertilize, overseed and provide notifications to residents.

### **803.05.04 Watering**

The work for this item shall include all labour, equipment, and material to water sod as required in the contract documents.

When extreme heat / drought conditions occur, and is verified by Environment Canada data, the Contractor may request in writing compensation for additional watering in these extreme weather circumstances. The Owner requires a formal letter from the Contractor, with backup from Environment Canada, and a copy of all water taking receipts and GPS water truck records during this heat stress duration. The claim for watering will only be considered for any watering over and above the minimum number of applications noted in the Sod Watering Table (Included in Sod Unit Pricing). Upon receipt of a claim for additional watering, all water taking receipts may be requested by the Contract Administrator for the entire duration of the 60-day maintenance period along with GPS records of watering trucks for backup.

## **CKSS 804 SEED AND COVER**

### **REFERENCES**

OPSS 804 – Seed and Cover

#### **804.01 Materials**

Seed mix shall be Certified Canada Grade No.1 grass seed.

##### **804.01.01 Permanent Seed Mix**

Permanent seed mix shall be as follows:

40% 98/85 Kentucky Bluegrass  
30% Creeping Red Fescue  
20% Perennial Ryegrass  
10% Hard Fescue

##### **804.01.02 Overseeding Seed Mix**

Overseeding seed mix shall be as follows:

60% Perennial Ryegrass  
20% Creeping Red Fescue  
20% Kentucky Bluegrass

##### **804.01.03 Hydroseeding Mix**

Same as permanent seed mix.

##### **804.01.04 Fertilizer**

Fertilizer shall comply with the provisions of the Canada Fertilizers Act and Fertilizer Regulations. Fertilizer shall be granulated 8-32-16 ration, complete synthetic slow-release with maximum 35% water soluble nitrogen.

#### **804.02 Construction**

##### **804.02.01 Application Rates for Seed, Fertilizer**

Fertilizer shall be applied at the rate recommended by the manufacturer specifications.

Seeding shall be applied at the rate recommended by the manufacturer specifications.

##### **804.02.02 Hydroseeding**

Hydroseeding shall be completed upon the removal of the tree protection fencing to cover areas inside the tree protection zones that are not to be disturbed by mechanical excavation or laid with sod and as directed by the Contract Administrator.

**804.03 Measurement for Payment**

Payment shall be on a square metre basis of area hydro-seeded, and shall be full compensation for all labour, equipment and material to do the work.

**804.04 Basis for Payment**

Payment at the contract price for the above item shall be full compensation for all labour, equipment and material to do the work.

Should growth of the seed not be acceptable to the Contract Administrator, the seeded area shall be weeded, cultivated and reseeded at the Contractor's own cost.

Maintenance holdback will be retained until secondary grass in the reseeded area is acceptable.

## **CKSS 805 TEMPORARY SEDIMENT AND EROSION CONTROL MEASURES**

### **REFERENCES**

OPSS 805 – Temporary Erosion and Sediment Control Measures

#### **805.01 Material**

##### **805.01.01 Sediment Fence**

Sediment fence shall be Terrafence by Terrafix Geosynthetics Inc., or approved equivalent installed to manufacturer's silt fencing specifications.

##### **805.01.02 Catchbasin Sediment Trap**

Sediment control for catchbasin lids shall SILTSACK® by Terrafix Geosynthetics Inc. or approved equivalent. The use of filter fabric placed in a frame will not be deemed equivalent.

##### **805.01.03 Silt Sock Sediment Control Device**

Silt sock sediment control device shall be Filtrex SiltSoxx® ORIGINAL or approved equivalent. The device shall be 200mm diameter or as specified elsewhere in the Contract Documents.

#### **805.02 Construction**

##### **805.02.01 Silt Sock Sediment Control Device**

The installation shall be as per manufacturer's specifications. The location shall be as shown on the Contract Drawings and as directed by the Contract Administrator. The sediment control device shall not be removed until the day the Contractor is placing sod.

#### **805.03 Maintenance**

Sediment fence, traps, and socks shall be inspected and cleaned daily for damage and / or sediment build-up.

#### **805.04 Measurement for Payment**

All erosion and sediment control measures shall be paid to the Contractor based on the following payment schedule:

- a) 40% for initial construction.
- b) 60% for removal.

##### **805.04.01 Catchbasin Sediment Trap**

For measurement purposes, a count shall be made for each sediment trap constructed, maintained and removed in a catchbasin lid. The use of filter fabric in the catchbasin lid is not an acceptable method of sediment control and will not be counted for payment.

##### **805.04.02 Sediment Fence**

Sediment fence shall be measure from end to end in plan view at locations placed on the site as directed by the Contract Administrator.

### **805.04.03 Silt Sock Sediment Control Device**

The measurement of this item shall be per lineal metre measured from end to end of the device.

## **805.05 Basis for Payment**

### **805.05.01 Catchbasin Sediment Trap**

The work for this item shall include all labour, material and equipment necessary to construct sediment traps in existing catchbasin lids adjacent to the downstream limits of the project or newly installed catchbasin lids as identified by the Contract Administrator.

Payment for this item will not be made if the sediment traps are not maintained by the Contractor.

There will be no additional payment to replace damaged sediment traps at the direction of the Contract Administrator where the Contractor's negligent maintenance was the result of the sediment trap failure.

### **805.05.02 Sediment Fence**

The work of this item shall be for all the equipment, labour, and materials required to install, maintain, and remove temporary sediment fence as per manufacturer's specifications.

### **805.05.03 Silt Sock Sediment Control Device**

The work for this item shall include all labour, equipment and materials required to install, maintain, and remove the silt sock sediment control device.

## **CKSS 850 TERRASEEDING**

### **850.01 Material**

The following specifications shall be applicable to all products and installation methods outlined below, regardless of brand name.

The following information pertains to Filtrexx™ GrowthMedia™ Blanket but construction and maintenance shall be applicable to an approved equivalent product selected by the Contractor to be utilized.

GrowthMedia™ used for Filtrexx™ GrowthMedia™ Blankets (or approved equivalent) shall be weed free and delivered from a well-decomposed source of organic matter. The media shall be produced using an aerobic composting process meeting or exceeding M.O.E. 101, C.C.M.E. Type “A” and Type “AA” regulations, and Compost Quality Assurance Program, (C.Q.A.) including time and temperature data indicating effective weed seed, pathogen and insect larva kill. The GrowthMedia™ shall be free of any refuse, contaminants or other materials toxic to plant growth. Non composted products will not be accepted. Test methods for the items shown below should follow USCC TMECC guidelines for laboratory procedures:

- a. PH – 5.0-8.0 in accordance with TMECC 04.11-A, “Electrometric pH Determinations for Compost”
- b. For seeded GrowthMedia™ Blankets, seed shall be incorporated at the time of application in the entire depth of the GrowthMedia™ blanket, at rates per sq. m as acceptable to the Contract Administrator. The following particle sizes shall also be followed: 100% passing a 50mm (2”) sieve, 99% passing 25mm (1”) sieve, minimum of 60% passing a 12.5mm (1/2”) sieve. All other testing parameters are to remain the same.
- c. Moisture content of less than 60% in accordance with standardized test methods for moisture determination
- d. Material shall be relatively free (i.e. less than 1% by dry weight) of inert or foreign man-made materials.
- e. A sample shall be submitted to the Contract Administrator for approval prior to being used and shall comply with all local, provincial and federal regulations

The GrowthMedia™ Blankets shall be placed at locations indicated on the drawings and as directed by the Contract Administrator. Unless otherwise specified, Filtrexx™ GrowthMedia™ Blanket shall be installed at a minimum depth of 75mm (3”) with Lock Down netting or adhesion additive in areas where the slope exceeds an angle that would be too steep to provide satisfactory binding of the blanket to the soil.

The Contractor shall routinely inspect the installation upon its completion and shall maintain the Filtrexx™ GrowthMedia™ Blanket in a functional condition at all times during the construction and maintenance phases of the project.

Should the GrowthMedia™ Blanket fail, separate or otherwise deteriorate, it shall be immediately repaired or replaced at the expense of the Contractor.

Seeding the Filtrexx™ GrowthMedia™ Blanket shall be incorporated for the entire depth of the blanket. Should germination of the seed not be satisfactory, the Contractor shall oversee the area.

The Contractor shall be a certified Filtrexx™ Installer as determined by Filtrexx™ Canada Inc. Certification shall be considered current if appropriate identification is provided during the time of bid or at time of application.

### **850.02 Measurement for Payment**

Payment for this item shall be by the square metre with a depth of 75mm (3") of exposed slope face for work completed. In support of this criteria, the Contractor shall provide proof that a 75mm (3") depth of GrowthMedia™ Blanket has been applied. Depth of the blanket may be measured in random locations at the time of application.

### **850.03 Basis for Payment**

The work for this item is to consist of the furnishing, installing, maintaining and terraseeding of existing and newly constructed portions of slope area that are unvegetated and includes the area disturbed by construction. Terraseeding shall consist of the application of a blanket with an approved seed mixture incorporated throughout the depth of the blanket.

## **CKSS 851 LANDSCAPING**

### **851.01 Construction**

Landscaped areas shall be restored to match original conditions or better. The Contractor shall use like materials wherever possible. All work that affects private property will require the Contractor to cooperate with the property owner(s) and to communicate the extent of the work, timing of impact and reinstatement.

### **851.02 Measurement for Payment**

Payment for this item shall be measured by the square meter for areas requiring restoration to Landscaping.

### **851.03 Basis for Payment**

The work for this item shall include all labour, equipment and materials required to reinstate landscaped areas instead of placement of sod.

## **CKSS 860 BIORETENTION FACILITIES**

### **860.01 Material**

#### **860.01.01 Geotextile**

Geotextile shall be Nilex 4535 non-woven geotextile or approved equivalent. The geotextile shall be installed as shown on the contract drawings and as directed by the Contract Administrator. Woven or non-woven geotextiles shall be as per CKSS 1860 and OPSS 1860.

#### **860.01.02 Storage Reservoir**

The storage layer shall be washed 20mm diameter clearstone.

#### **860.01.03 Choker Layer**

The choker layer shall be 'High Performance Bedding' comprised of clean, angular aggregate screened between 6 and 10mm.

#### **860.01.04 Filter Media**

Filter media shall be as per CKSS 1870. The Filter media shall be either Blend A or Blend B as specified in the contract documents.

#### **860.01.05 Mulch**

Mulch shall be double shredded pine mulch placed on site as shown on the contract drawings and as directed by the Contract Administrator.

### **860.02 Construction**

Filter media shall be installed in 200mm lifts and consolidated by thoroughly wetting the material prior to placing subsequent lifts.

Filter media shall not be installed until approval is received from the Contract Administrator, approved filter media mixes shall be installed immediately prior to installation of the plantings and full stabilization of the catchment areas.

Geotextiles placed at locations shown throughout the drawings shall be secured in place to prevent wrinkling and overlap a minimum of 500mm in the direction of drainage.

Sediment controls shall be installed prior to the commencement of construction to prevent runoff from contaminating excavated surface of the native soils, filter media, or the aggregate base courses.

The LID systems shall not be placed on-line until all landscaping/plantings are established and well rooted. Opening of the system shall be completed upon approval of the Contract Administrator.

Final grade of the bioretention area represent the finished surface of the mulch/stone surface treatments. Filter media shall be graded to accommodate the proposed surface treatments.

**860.03 Basis for payment**

Payment shall be for all labour, equipment and the supply, placement and compaction of filter media at locations as shown on the Contract Drawings and as directed by the Contract Administrator.

Filter media installed without receiving testing clearance from the Contract Administrator shall be removed at the Contractor's expense.

## **CKSS 914 WATERPROOFING BRIDGE DECKS WITH HOT APPLIED ASPHALT MEMBRANE**

### **REFERENCES**

OPSS 914 – Waterproofing Bridge Decks with Hot Applied Asphalt Membrane

#### **914.01 Measurement for Payment**

The unit prices bid for this item, multiplied by the actual square meters of waterproofing satisfactorily placed as measured in the field.

#### **914.02 Basis for Payment**

The work for this item shall include all costs, such as but not necessarily limited to, all public safety protection, all paint, labour, materials, preparation of concrete deck surfaces and approach slabs, tack coating, membrane reinforcement fabric, hot applied rubberized asphalt waterproofing membrane and application of protection boards complete per OPSS 914.

## **CKSS 960 RETAINING WALL**

### **960.01 Material**

For new installations acceptable products are as follows;

- PISA2® (natural colour) by Unilock,
- GRANDE® Wall by Permacon,
- SienaStone™ by Unilock.

### **960.02 Construction**

In the event that additional retaining wall blocks are required to replace those salvaged from the site, the Contractor shall supply replacement materials without additional cost.

All work that affects a private retaining wall will require the Contractor to cooperate with the property owner(s) and to communicate the extent of the work, timing of impact and reinstatement, and to obtain a satisfactory sign off from the property owner(s) that the work of reinstatement has been completed to the property owner(s)'s satisfaction.

The maximum allowable height for PISA2® wall shall be 840mm (2.75ft) with a maximum retained slope of 3 metres horizontal to 1 metre vertical.

The maximum allowable exposed height for GRANDE® Wall shall be 2800mm (9.18ft) with a maximum retained slope of 3 metres horizontal to 1 metre vertical.

The maximum allowable exposed height for SienaStone™ Wall shall be 1000mm (3.28ft) with a maximum retained slope of 3 metres horizontal to 1 metre vertical.

The maximum heights listed above apply to gravity walls without geogrid restraint, the inclusion of geogrid in the retaining wall system shall be approved by the Owner.

Granular bedding, backfill and drainage shall be as per the manufacturer's specifications.

The Contractor shall submit shop drawings prepared by a Professional Engineer licensed in the Province of Ontario for review by the Contract Administrator.

### **960.03 Measurement for Payment**

Payment for this item shall be measured by the square metre of wall face from the top of the granular bedding to the top of the coping unit along the entire length of the wall.

### **960.04 Basis for Payment**

The work for this item shall include all labour, equipment and material necessary to install precast concrete retaining wall blocks as indicated on the contract drawings as directed by the Contract Administrator.

The cost for granular bedding and backfill, geogrid, filter cloth and sub-drain for drainage behind the wall shall be included in the unit cost for this item.

## **CKSS 1010 MATERIAL SPECIFICATIONS – BASE, SUBBASE, SELECT SUBGRADE, AND BACKFILL MATERIAL**

### **REFERENCES**

OPSS 1001 – Material Specification for Aggregates – General

OPSS 1010 – Material Specification for Aggregates – Base, Subbase, Select Subgrade, and Backfill  
Material

RWSSP 1010 – Granular “B”

#### **1010.01.01 Granular B**

The gradation for Granular B shall be as per RWSSP 1010, “Granular B”.

#### **1010.01.02 ASTM No. 8 Gradation**

Sieve Size	Percent Passing
12.5mm	100
9.5mm	85 to 100
4.75mm	10 to 30
2.36mm	0 to 10
1.16mm	0 to 5

## **CKSS 1303**

# **MATERIAL SPECIFICATIONS – ADMIXTURES FOR CONCRETE**

### **REFERENCES**

OPSS 1303 – Material Specifications for Admixtures for Concrete

#### **1303.01 Curing Compound**

Curing compound shall meet the requirements of OPSS Form 1315 - Material Specification for White Pigmented Membrane Curing Compound for Concrete.

#### **1303.02 Coloured Concrete**

As required by the Contract Documents or as directed by the Contract Administrator the following specifications shall apply for the supply of coloured concrete pigment.

- a) “Black” coloured concrete shall refer to the following pigment: colour XB5599 “Charcoal Black”, by Davis Colors Inc., [www.daviscolors.com](http://www.daviscolors.com)
- b) “Red” coloured concrete shall refer to the following pigment: colour palette # 1117 “Tile Red”, by Davis Colors Inc., [www.daviscolors.com](http://www.daviscolors.com)
- c) On the Queen Street Corridor the “Red” coloured concrete shall refer to the following pigment: colour palette # 160 “Sunset Rose”, by Davis Colors Inc., [www.daviscolors.com](http://www.daviscolors.com)
- d) Portland to pigment ratio shall be 5%, unless noted in the Schedule of Unit Prices
- e) Only a clean uncoloured curing compound may be used which will not affect the final colour of the pigmented concrete. A white pigmented curing compound may be used only upon natural, unpigmented concrete.

## **CKSS 1350**

### **MATERIAL SPECIFICATIONS – CONCRETE**

#### **REFERENCES**

OPSS 1350 – Material Specifications for Concrete – Materials and production

#### **1350.01 Material**

All concrete supplied shall comply with the requirements of the latest edition of C.S.A. Standard A23.1, "Concrete Materials and Methods of Concrete Construction".

All concrete supplied under this specification shall contain the following mix proportions:

- a) Water / cement ratio shall be 0.45 w/cm for C-2 Class of Exposure in accordance with C.S.A. Standard A23.1, Table 1, Definitions for C, F and N Classes of Exposure.
- b) Maximum nominal size of coarse aggregate shall not exceed 20mm and gradation limits shall meet the requirements of C.S.A. Standard A23.1, Section 4.2.3.3.2 / 4.2.3.4.2 Grading.
- c) Air entrainment shall be 5-8% in accordance with OPSS 1303, "Material Specification for Air Entrainment and Chemical Admixtures for Concrete".
- d) Minimum compressive strength for Normal and General Use (GU) Portland Cement Concrete shall be 32 MPa at 28 days. Alternative cement types, such as High-Early Strength (HE), may be considered by the Contract Administrator on a project by project basis.

## **CKSS 1851 MATERIAL SPECIFICATIONS – CATCHBASIN QUALITY CONTROL DEVICES**

### **REFERENCES**

[cbshield.com](http://cbshield.com)

#### **1851.01      General**

The catchbasin quality control device shall be certified an approved verified technology by [ETV Canada](#).

The catch basin insert shall facilitate removal of sediment from stormwater by settling in the catch basin sump during frequent rain and snowmelt events. The insert shall prevent resuspension of captured material during higher flow events, with sediment to remain in place until suitably removed with appropriate catch basin cleaning equipment. The insert shall not impede flows through the catch basin, and shall not be prone to blockage.

#### **1851.02      Total Suspended Solids and Particle Size Distribution**

The catch basin insert shall enhance and not impede the catch basin's ability to capture sediment. Depending on site conditions, the system shall generally be capable of capturing and retaining a long term average of 50% to 60% of incoming total suspended solids (TSS) loading. Sediment/TSS removal calculations shall be based on the particle size distribution associated with the ETV Canada definition of test sediment as outlined in their protocol for testing of Oil Grit Separator type devices.

The catch basin insert performance shall be determined through independent laboratory testing with protocols based on (and in general conformance with) the Canadian ETV program's protocol for TSS removal and scour for Oil Grit Separator type devices (as authored by Toronto Region Conservation Authority, revised June 2014).

Alternative long term removal rates associated with assuming a different PSD for incoming TSS (such as for sediment consistent with the City of Toronto's Wet Weather Flow Management Guidelines) will be provided by CB Shield Inc. if assumed in design calculations.

## **CKSS 1860 MATERIAL SPECIFICATIONS – GEOTEXTILES**

### **REFERENCES**

OPSS 1860 – Material Specifications for Geotextiles

#### **1860.01 Material**

##### **1860.01.01 Woven and Non-Woven Geotextiles**

Woven slit film and non-woven heat bonded geotextile fabrics shall not be allowed for use as part of an infiltration system.

Geotextiles shall be as per OPSS 1860 Class II geotextile fabrics.

## **CKSS 1861 MATERIAL SPECIFICATIONS – GEOGRID**

### **1861.1 Physical Requirements**

The geogrid shall meet the minimum physical characteristics outlined below in Table 1.

Table 1 – Physical Property Requirements

Property	ASTM Test Method	Unit	Biaxial Geogrid	Triaxial Geogrid
Resistance to Chemical degradation	D 4355	%	100%	100%
Radial stiffness at 0.5% strain		kN/m	284.9	200
Flexural stiffness	D 7748	mg-cm	250,000	-
Aperture stability		kg-cm/deg	3.4	3.0
Junction efficiency	D 6637-10, D7737-11	%	93	93

Specific geogrid where required shall be specified elsewhere in the contract documents.

### **1861.2 Measurement for Payment**

The geogrid will be measured in plan view by the square metre for each layer of geogrid placed.

## CKSS 1870 MATERIAL SPECIFICATIONS – BIORETENTION FILTER MEDIA

### 1870.01 Physical Requirements

The filter media should be premixed prior to arriving on-site and shall be mixed at the following proportions.

	<b>Blend A</b>	<b>Blend B</b>
Application	Drainage rate priority	Water quality treatment priority
Proportions	3 parts sand to 1 part organic matter	3 parts sand, 2 parts topsoil, 1 part organic matter

Filter media shall be dried ground and tested to ensure following specifications are met.

Characteristic	Criterion	Recommended test method
Particle-size distribution (PSD)	< 25% silt and clay sized particles (smaller than 0.05 mm) combined; 3 to 12% clay sized particles (0.002 mm or smaller)	ASTM D6913/D6913M, Standard Test Methods for Particle-Size Distribution (Gradation) of Soils Using Sieve Analysis (pebble to sand fraction); and ASTM D7928, Standard Test Method for Particle-Size Distribution (Gradation) of Fine-Grained Soils Using the Sedimentation (Hydrometer) Analysis (silt and clay fraction).
Organic matter (OM)	3 to 10% by dry weight	ASTM F1647, Standard Test Methods for Organic Matter Content of Athletic Field Rootzone Mixes.
Phosphorus, plant-available or extractable	12 to 40 ppm	As measured by the 'Olsen' method for alkaline and calcareous soils (common in Ontario). Alternatives include 'Mehlich I or III', or 'Bray', which is better suited to acidic to slightly alkaline and non-calcareous soils. NB: Results from different test methods are not directly comparable.
Cationic exchange capacity (CEC)	> 10 meq/100 g	ASTM D7503, Standard Test Methods for Measuring the Exchange Complex and Cation Exchange Capacity of Inorganic Fine-Grained Soils.
Hydraulic conductivity, saturated ( $K_f$ )	> 75 mm/hr; Blend A > 25 mm/hr; Blend A < 300 mm/hr; Blend A and B	ASTM D2434, Standard Test Method for Permeability of Granular Soils (Constant Head), when the sample is compacted to 85% of its maximum dry density in accordance with ASTM D698, Standard Test Methods for Laboratory Compaction Characteristics of Soil Using Standard Effort.

#### 1870.01.01. Sand

Sand for bioretention facilities shall be washed clean and free of toxic materials. The pH shall be less than or equal to 7.0.

Sand shall meet the particle size distribution below.

<b>Sieve</b>	<b>Percent Passing</b>
9.5 mm	100
4.75 mm	95 – 100
2.36 mm	80 – 100
1.18 mm	50 – 85
0.60 mm	25 -50
0.30 mm	5 - 30
0.15 mm	0 – 10
0.075 mm	≤ 3

### **1870.01.02. Topsoil**

Topsoil may be material that was stripped from the project site and stored in stockpiles for re-use, or material imported to the site from a supplier provided the physical and chemical characteristics are within acceptable ranges.

The following criteria shall be required of topsoil for use in bioretention media.

- Shall be free from toxic material and roots, stones or debris over 50 mm (2") in diameter;
- Shall not have been passed through sieves or screens smaller than 50 mm (2") to avoid eliminating peds;
- For use as planting soil for a vegetated stormwater practice , the topsoil must contain a minimum of 5% organic matter by dry weight or be amended so, through addition of an organic soil conditioner;
- For use in producing bioretention filter media Blend B (water quality treatment priority), the topsoil must contain at least 9%, and not greater than 36% clay-sized particles and at least 2% organic matter by dry weight.
- pH of between 6.0 and 8.0;
- sodium absorption ratio less than 15;
- cationic exchange capacity greater than 10 milliequivalents per 100 grams (meq/100 g).

### **1870.01.03. Organic Component**

The organic material may be comprised of compost or wood chips. Compost shall comply with mandatory Ontario Compost Quality Standards for Category 'AA'. Compost shall be certified to meet quality parameters recommended under the Compost Council of Canada Compost Quality Alliance (CQA) program. The compost material shall be low in phosphorus typically created from feedstocks including yard, leaf, and wood waste excluding manures, biosolids and food scraps.

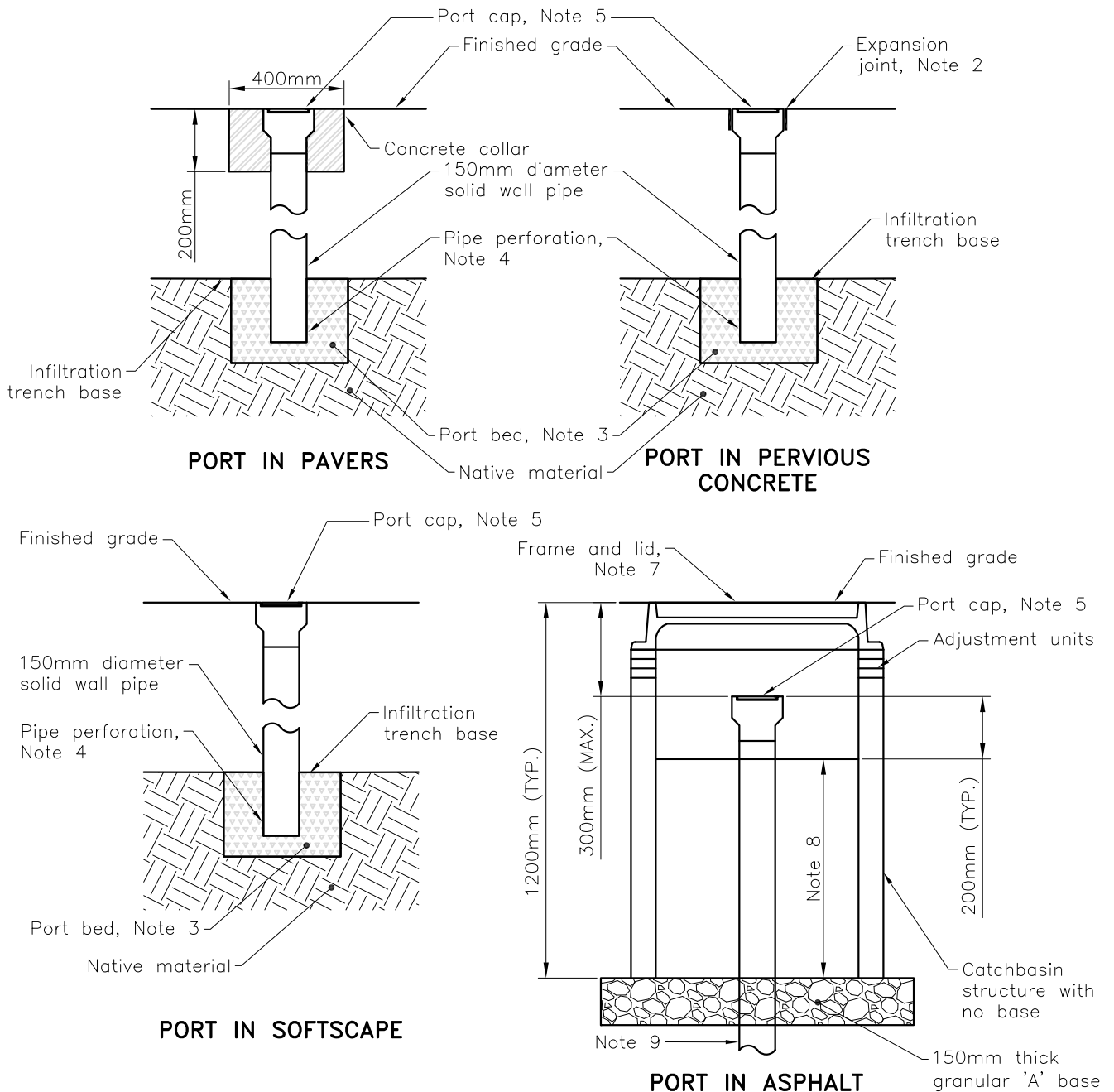

**NOTES:**

1. This standard drawing shall be read in conjunction with CKSD 570.010 and 570.020 drawings.
2. Expansion joint to be wrapped around the entire perimeter of the well head.
3. Port bed to be 300mm diameter to a depth of 200mm filled with 20mm diameter clear stone.
4. The bottom 150mm of solid pipe to be drilled with 10 evenly spaced 13mm diameter holes.
5. Embedded flush mounted observation port cap (bolt down) H-20 traffic rated.
6. All dimensions are in millimetres unless otherwise shown.
7. Frame and grate as per OPSD 401.030.
8. To be filled with 20mm clear stone.
9. Pipe to extend down to port bed as shown in details above.

Plotted by: JonS    Filename: S:\General\01-04-915 Staff Committees\Specifications Committee\Contract Documents Upkeep\Standard Drawings\CKSD - 820.010.dwg



DRAWING TITLE:

**OBSERVATION PORT FOR STORMWATER  
MANAGEMENT LID**

LAST REVISED  
March 12, 2019

PLOT DATE  
October 29, 2020

DWG No.  
**CKSD - 820.010**

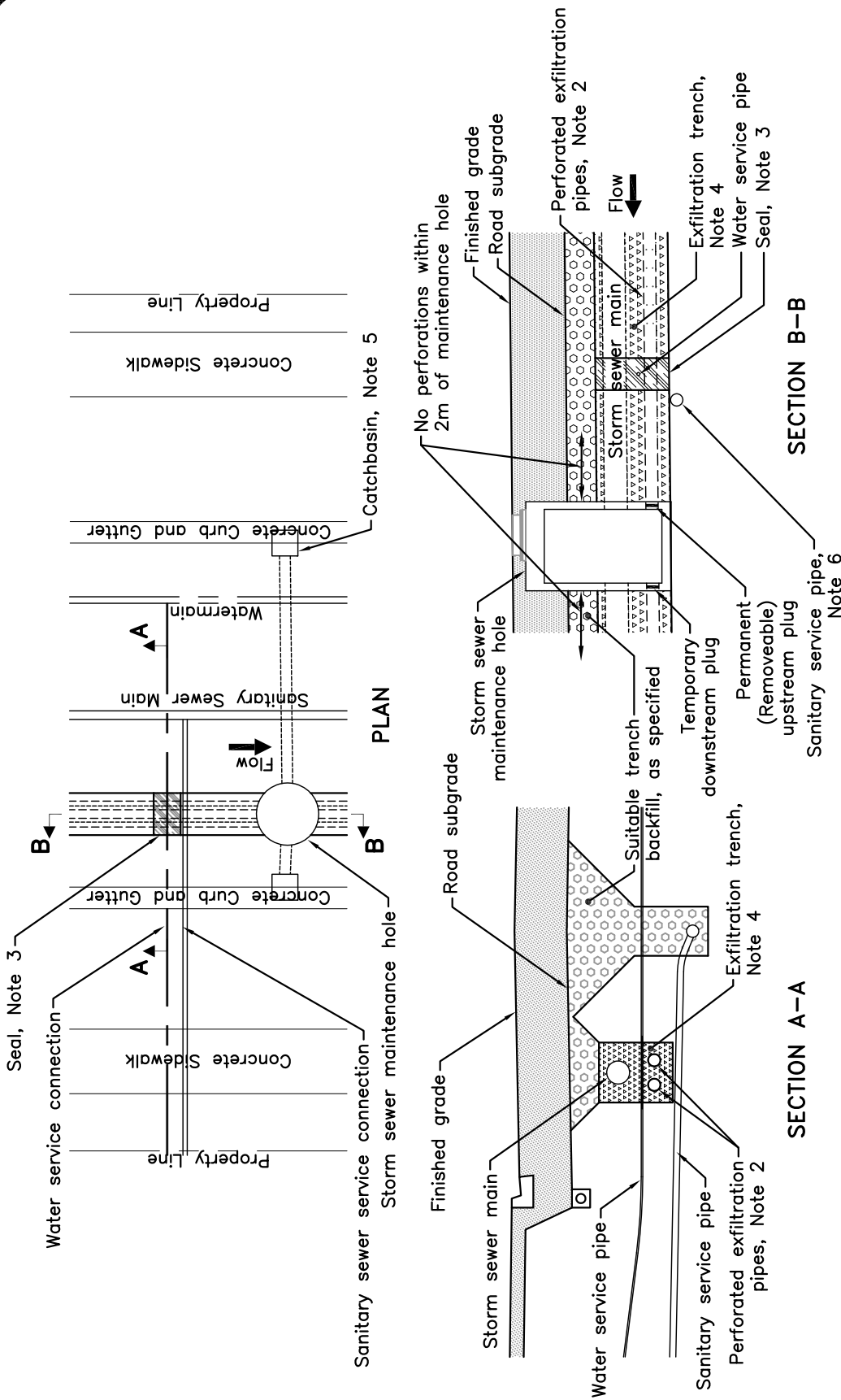

- NOTES:
1. This standard drawing shall be read in conjunction with City of Kitchener development manual standard drawings for typical road cross sections.
  2. No perforations within 2.0 metres of a maintenance hole structure, see CKSD 821.012 for connection details.
  3. Seal shall be either clay or low strength concrete as per OPSD 802.095, extending up to the top of the exfiltration trench.
  4. See CKSD 821.011 for details of the exfiltration trench.
  5. Catchbasins draining to a perforated pipe system shall utilize a quality control device.
  6. Sanitary services within the exfiltration trench shall also be sealed with clay or low strength concrete.
  7. All dimensions are in millimetres unless otherwise shown.

Plotted by: jons Filename: C:\AutoCAD Civil3D\Detail Drawings\CKSD - 821.010.dwg



DRAWING TITLE:

# PERFORATED PIPE EXFILTRATION SYSTEM

LAST REVISED  
October 26, 2017

PLOT DATE  
November 02, 2017

DWG No.  
**CKSD - 821.010**

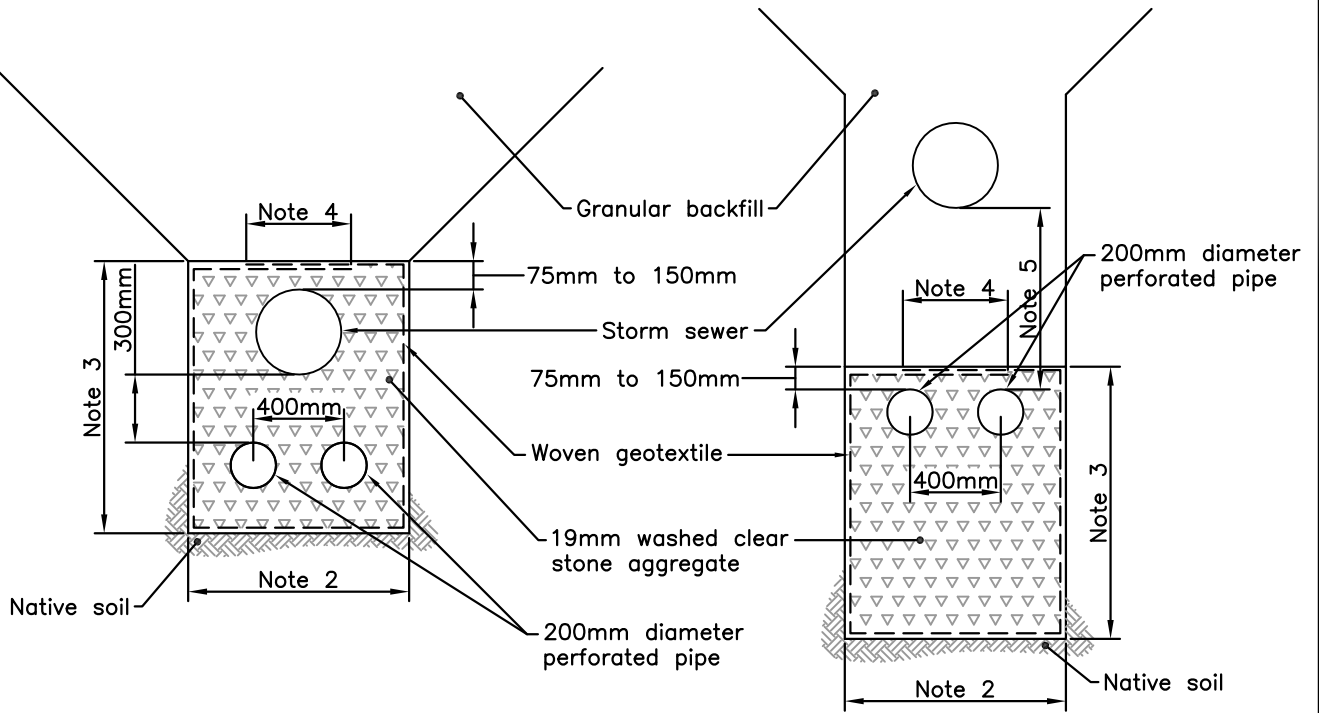

**COMBINED EXFILTRATION TRENCH**

**SEGREGATED EXFILTRATION TRENCH**

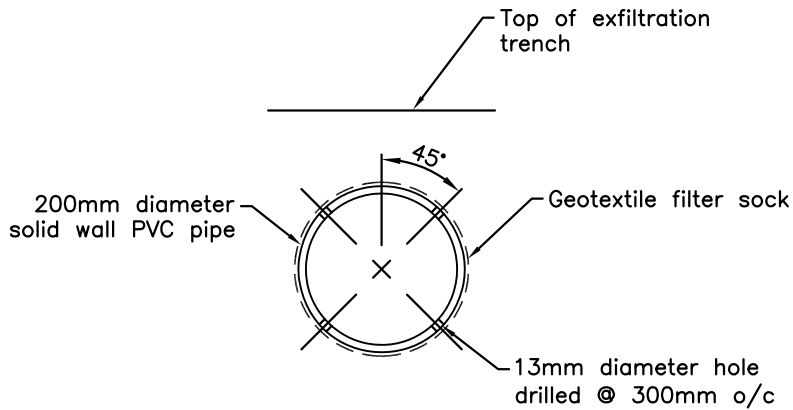

**PERFORATED PIPE**

**NOTES:**

1. This standard drawing shall be read in conjunction with CKSD 821.010.
2. Minimum width is 1000mm, maximum width based on site specific design.
3. Minimum height is 1200mm, maximum height based on site specific design.
4. Geotextile to have a minimum 500mm overlap at the top of the trench.
5. The offset will be based on site specific design.
6. All dimensions are in millimetres unless otherwise shown.

Plotted by: JonS    Filename: C:\AutoCAD Civil3D\Detail Drawings\CKSD - 821.011.dwg



DRAWING TITLE:

**EXFILTRATION TRENCH WITHIN THE ROADWAY**

LAST REVISED  
June 06, 2018

PLOT DATE  
December 06, 2018

DWG No.  
**CKSD - 821.011**

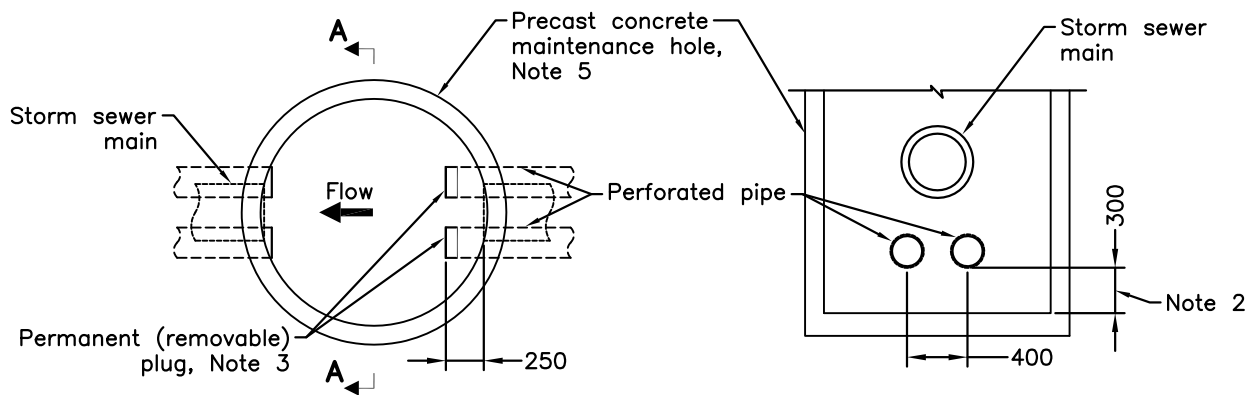

MAINTENANCE HOLE CONNECTION

SECTION A-A

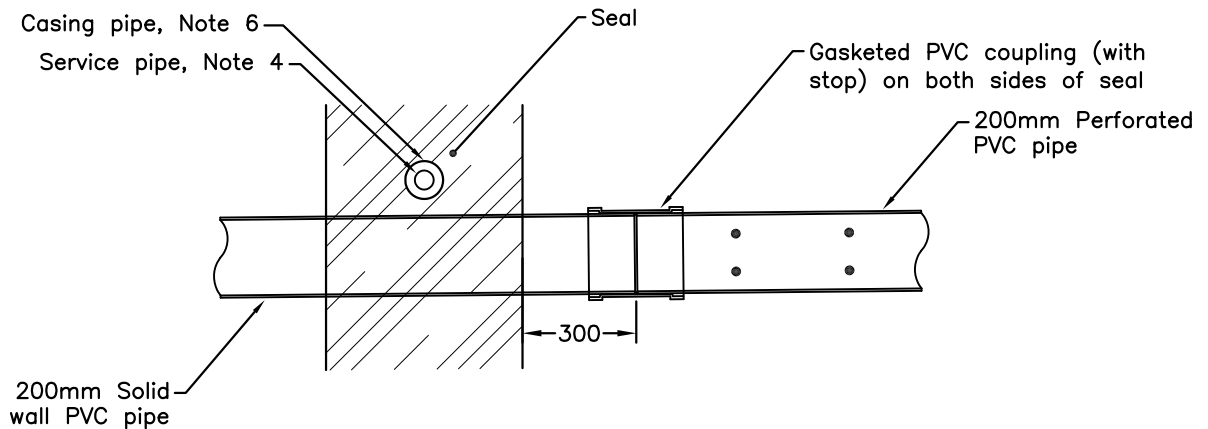

PIPE CONNECTION

NOTES:

1. This standard drawing shall be read in conjunction with CKSD 821.010.
2. Maintenance holes with perforated pipe connections shall not be benched.
3. The permanent plug shall be a screw type cap removable for maintenance.
4. Service pipe refers to any pipe crossing the trench, regardless of what is being carried through the pipe.
5. The minimum maintenance hole diameter shall be 1500mm.
6. Casing pipe shall be as per CKSS 410, minimum diameter 100mm.
7. All dimensions are in millimetres unless otherwise shown.

Plotted by: JonS Filename: C:\AutoCAD Civil3D\Detail Drawings\CKSD - 821.012.dwg



DRAWING TITLE:

**PERFORATED PIPE CONNECTION DETAIL**

LAST REVISED  
October 30, 2018

PLOT DATE  
November 30, 2018

DWG No.  
**CKSD - 821.012**

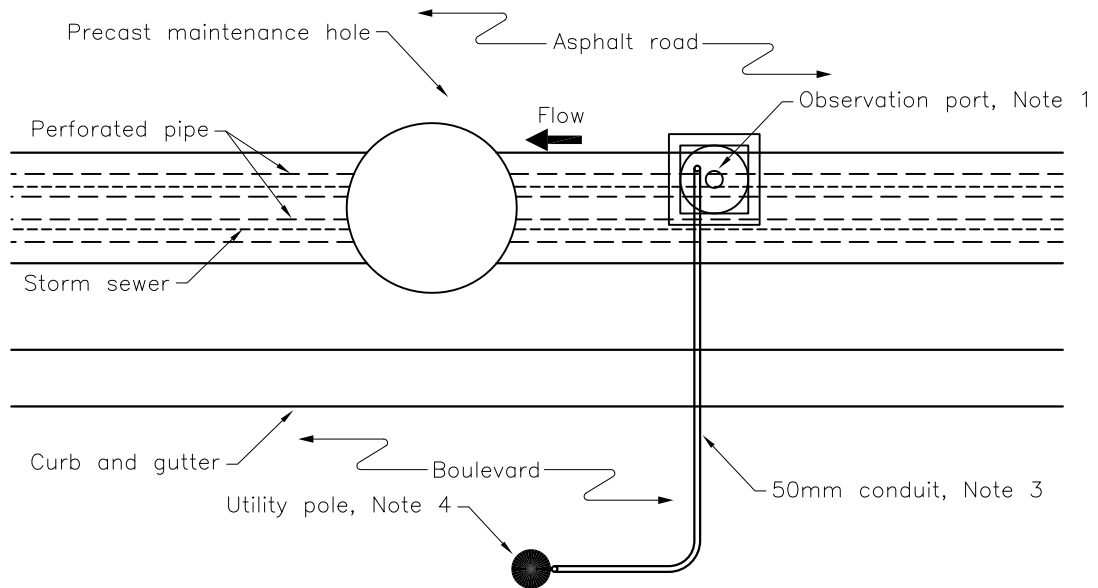

**CONDUIT LAYOUT**

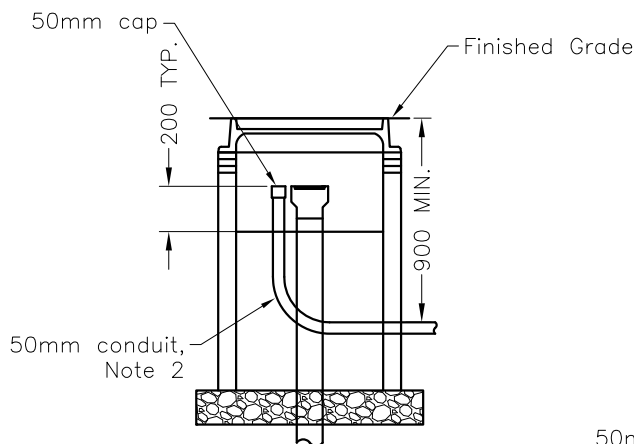

**CONDUIT RISER AT  
OBSERVATION PORT**

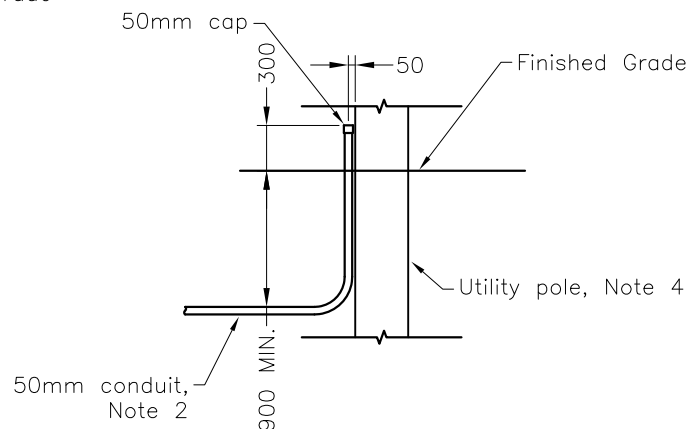

**CONDUIT RISER AT  
UTILITY POLE**

**NOTES:**

1. This standard drawing shall be read in conjunction with CKSD 820.010.
2. Conduit shall be as per OPSS 603 and CKSS 603.
3. Conduit shall be from observation port to nearest utility pole.
4. If there are no utility poles within 100m a 150mm x 150mm post shall be provided.
5. All dimensions are in millimetres unless otherwise shown.

Plotted by: JonS    Filename: C:\AutoCAD Civil3D\Detail Drawings\CKSD - 822.010.dwg



DRAWING TITLE:

**CONDUIT INSTALLATION FOR OBSERVATION  
PORT**

LAST REVISED  
March 12, 2019

PLOT DATE  
March 12, 2019

DWG No.  
**CKSD - 822.010**

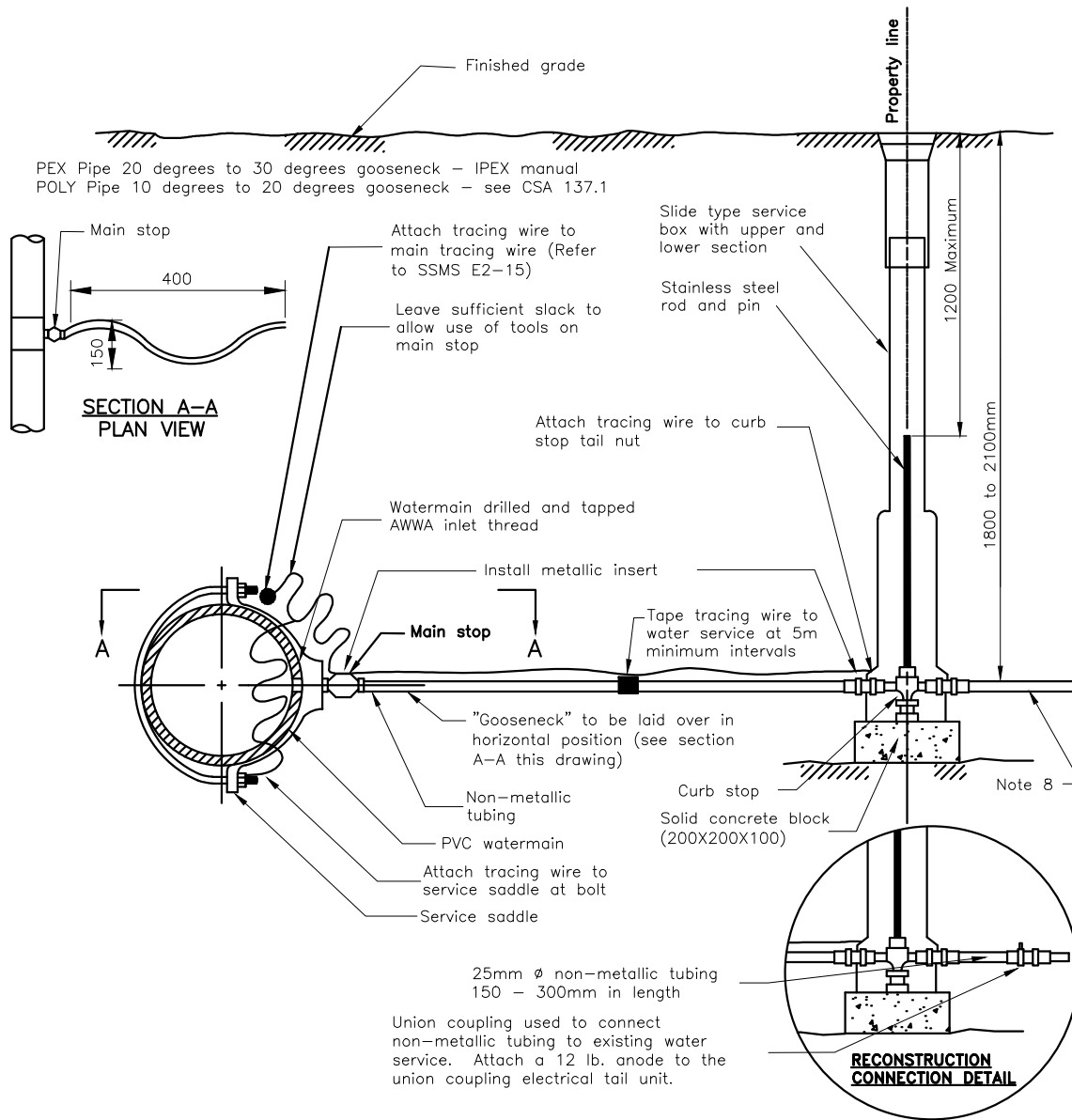

**NOTES:**

1. Connections to plastic mains to be made using service saddles or factory made tees.
2. Union couplings will not be permitted unless the service length exceeds 20m and unions shall not be placed underneath roadways.
3. All water services gooseneck to be installed as per manufacturer's specifications.
4. All dimensions are in millimeters unless otherwise shown.
5. Corrosion protection shall be affixed as per ssms standard specifications for watermain construction.
6. The tracing wire is to be connected at three locations: the main tracing wire, the saddle/main stop (at bolt) and the curb stop (at tail nut).
7. For reconstruction do not connect the private side tracing wire or metallic service to the curb stop.
8. When the existing service is metallic an anode shall be connected to the existing metallic service on the private side of the curb stop.

Plotted by: WilliamK Filename: S:\General\01-04-915 Staff Committees\Specifications Committee\Contract Documents Upkeep\Standard Drawings\CKSD - 1104.010.dwg



DRAWING TITLE:

**NON-METALLIC WATER SERVICE CONNECTION DETAIL  
FOR NON-METALLIC WATERMAIN 25 AND 50mm  
DIAMETER SIZES**

LAST REVISED

December 05, 2019

PLOT DATE

December 05, 2019

DWG No.

**CKSD - 1104.01**