

TOP VIEW

— FLOW —>

NOTE: METER MUST BE INSTALLED ON HORIZONTAL PLAIN

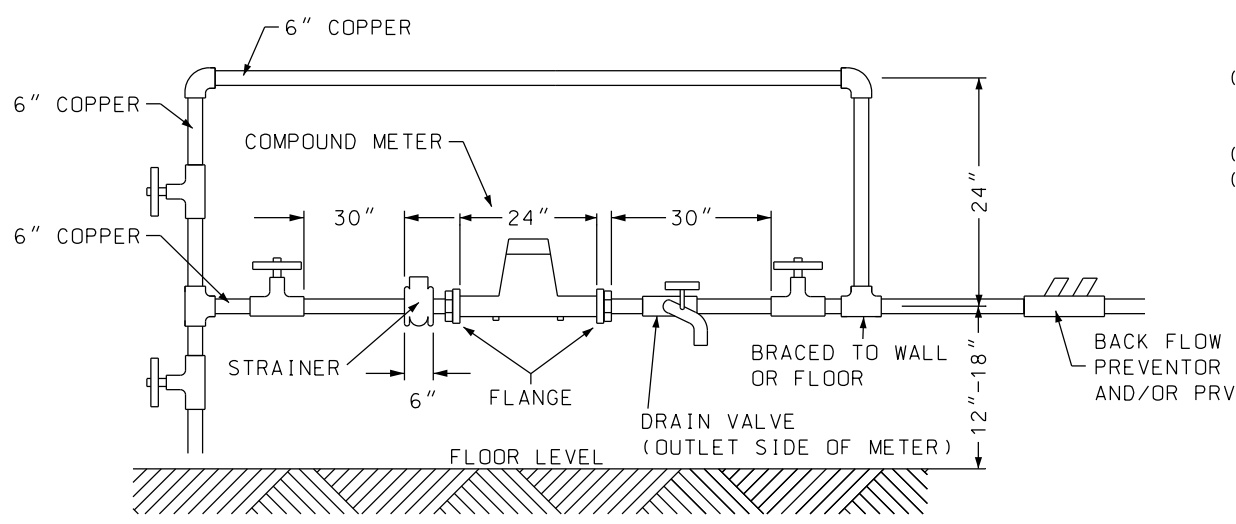

FRONT VIEW (BY-PASS IN VERTICAL POSITION)

NOTES TO BUILDER AND PLUMBER

- (1) ALL METERS MUST BE ACCESSIBLE FOR READING AND REPLACEMENT. ANY OBSTRUCTIONS WILL BE BASIS FOR TERMINATION OF THE WATER SUPPLY.
- (2) ALL WATER METERS ARE MARKED WITH A FLOW DIRECTIONAL ARROW. PLEASE ENSURE ARROW CORRESPONDS WITH WATER FLOW.
- (3) REMOVE METER FROM SERVICE BEFORE SOLDERING. HEAT AND SOLDER WILL DAMAGE THE INNER COMPONENTS OF THE WATER METER. **AN INVOICE WILL BE FORWARDED FOR ANY DAMAGED METERS.**
- (4) ALL METER SETS MUST HAVE A RISING STEM GATE VALVE BEFORE AND AFTER AS WELL AS A BY-PASS WITH A RISING STEM GATE VALVE AS THE DRAWING INDICATES.
- (5) ALL WATER METERS MUST BE INSTALLED USING THE SUPPLIED METER FLANGES AND GASKETS.
- (6) BACKFLOW PREVENTORS AND PRESSURE REDUCING VALVES **MUST BE INSTALLED AFTER METER SET.**
- (7) BACKFLOW PREVENTOR PREMISE VALVES MUST BE INSTALLED WITHIN 3m (10') OF THE WATER METER AND EXCESSIVE PIPING IN BETWEEN THESE DEVICES MUST BE LABELED "NO CONNECTION PERMITTED".
- (8) 2' CLEARANCE ABOVE AND 3' CLEARANCE IN FRONT OF THE WATER METER IS MANDATORY.
- (9) METER TO BE SET ON A CEMENT PAD.
- (10) 6" BY-PASS TO BE INSTALLED 2' ABOVE OR BESIDE THE WATER METER ON A HORIZONTAL LINE FOR AN ADDITIONAL METER IF AN INCREASE OF WATER SUPPLY IS NEEDED.
- (11) BY-PASS TO BE NO MORE THAN 4' OFF FLOOR.
- (12) BY-PASS TO BE COPPER.
- (13) THE CITY WILL SUPPLY ONE 6" COMPOUND WATER METER, ONE 6" STRAINER **(TO BE INSTALLED BEFORE WATER METER AS SHOWN)**, METER FLANGES, GASKETS AND NUTS/BOLTS FOR METER SET.
- (14) WATER METER AND STRAINER TO BE INSTALLED BY THE PLUMBING CONTRACTOR TO THE REQUIREMENTS OF THE CITY OF KITCHENER.
- (15) METER/STRAINER MEASUREMENTS MAY VARY.
- (16) CALL 519-741-2600 X 4537 FOR FURTHER ASSISTANCE.

6" COMPOUND METER SET - STANDARD		 Kitchener Utilities
6" COMPOUND METER SET - BFP		
6" COMPOUND METER SET - PRV		
DRAWN	RJB	SCALE N.T.S.
CHECKED		DATE May 22 2015